

ECE 697 Delta-Sigma Converters Design

Lecture#14 Slides

Vishal Saxena
(vishalsaxena@u.boisestate.edu)

CIFB (Cascade of Integrators with Distributed Feedback)

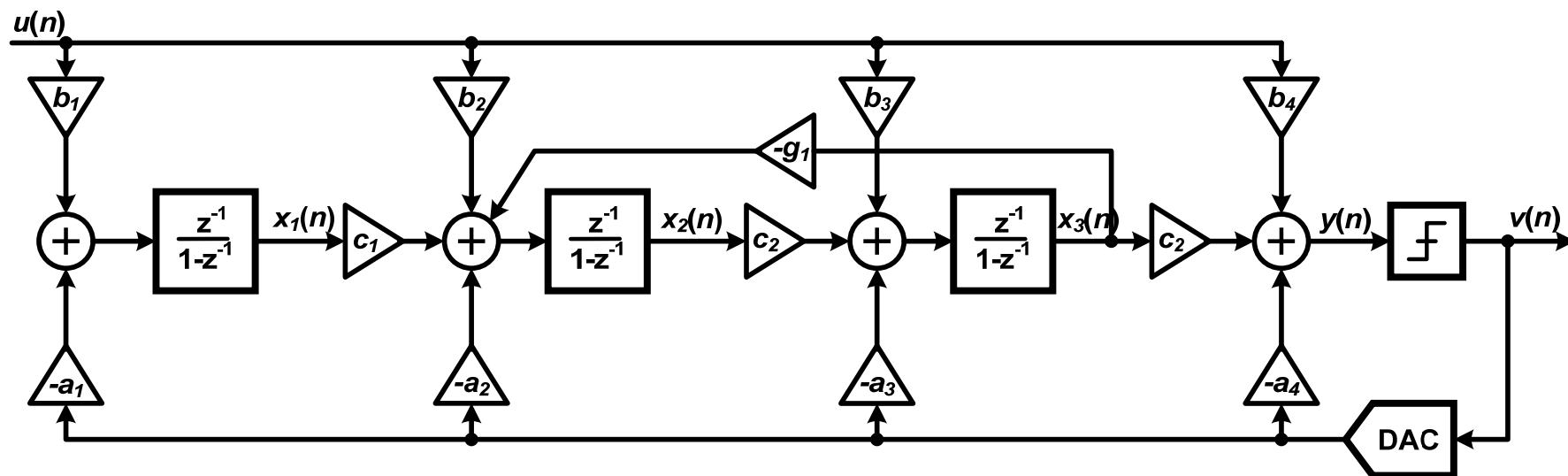

□ Cascade of delaying integrators:

- ✓ Feedback coefficients \mathbf{a} 's realize the zeros of L_1 and thus the NTF and STF poles.
- ✓ Feed-in coefficients \mathbf{b} 's determine zeros of L_0 and thus the STF zeros.
- ✓ State scaling coefficients \mathbf{c} 's are used for dynamic range scaling.
- ✓ Implements Butterworth NTF.

CRFB (Cascade of Resonators with Distributed Feedback)

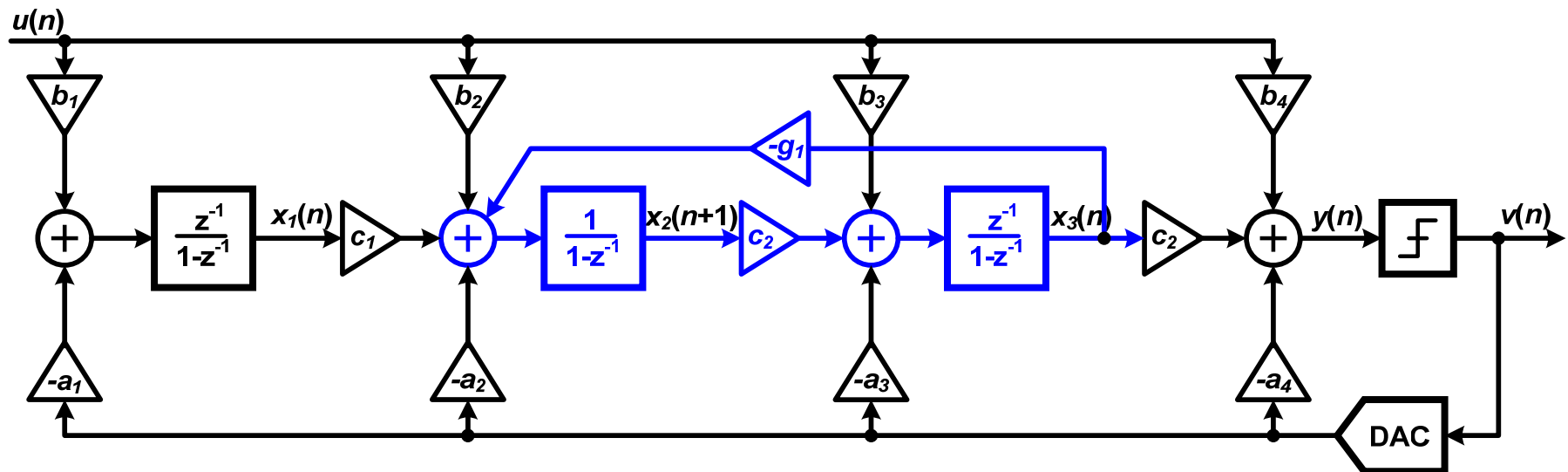

- ❑ Combine a non-delaying and a delaying integrator with local feedback around them, to form a stable resonator.
 - ✓ Local feedback coefficients g 's realize the complex zeros in the NTF.
 - ✓ Implements NTF with complex zeros. $z_i = e^{\pm j\sqrt{g_1}}$
- ❑ For odd-order, use an integrator in the front to avoid noise coupling due to g .

CIFB with Resonators

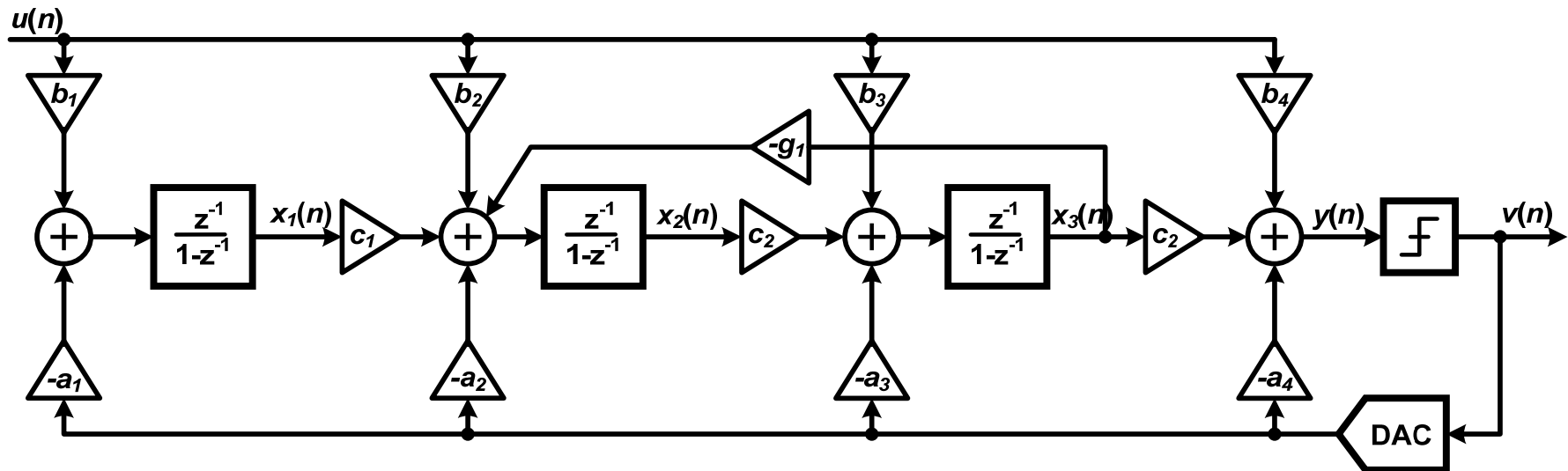

- ❑ A resonator can also be formed with two delaying integrators
 - ✓ Resonator poles outside the unit circle. $z_i = e^{1 \pm j\sqrt{g_1}}$
 - ✓ Locally unstable but works fine in a stable loop-filter.
- ❑ Relaxes settling requirements on the op-amps and implements complex NTF zeros.

CIFF (Cascade of Integrators with Feed-Forward Summation)

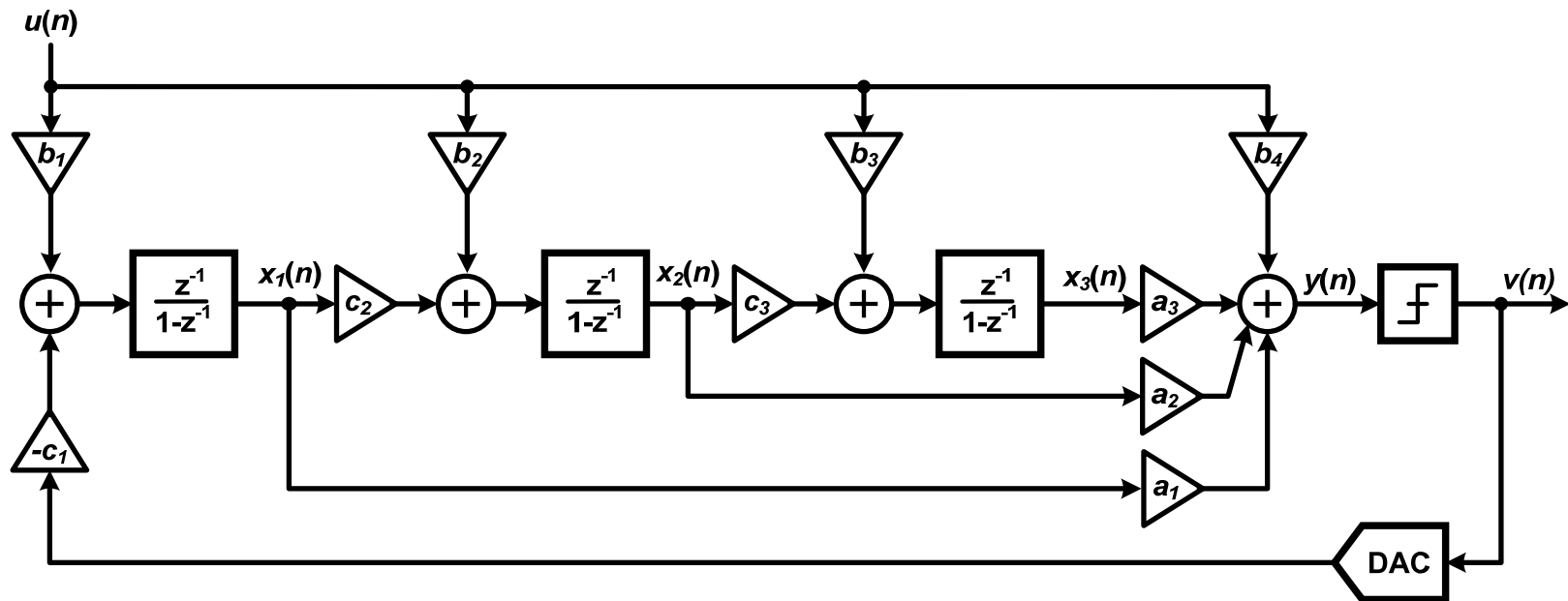

□ Cascade of delaying integrators:

- ✓ Feedforward coefficients **a**'s realize the zeros of L_1 and thus the NTF and STF poles.
- ✓ Feed-in coefficients **b**'s determine zeros of L_0 and thus the STF zeros.
- ✓ State scaling coefficients **c**'s are used for dynamic range scaling.
- ✓ Implements Butterworth NTF.

CRFF (Cascade of Resonators with Feed-Forward Summation)

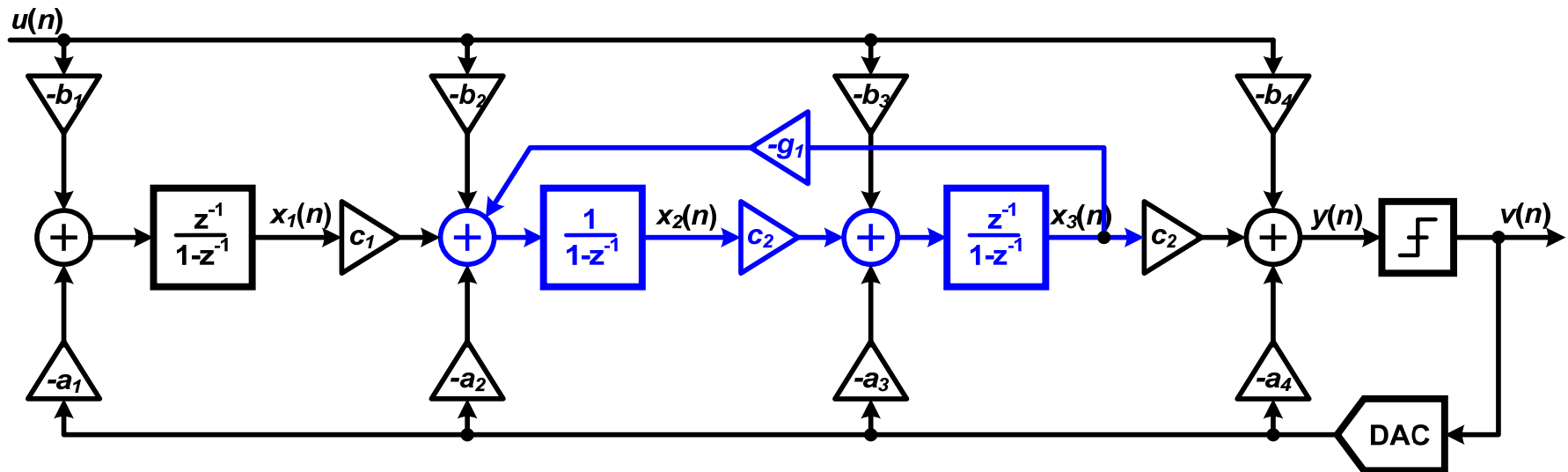

- ❑ Use resonators with feedforward summation.
 - ✓ Local feedback coefficients g 's realize the complex zeros in the NTF.
 - ✓ Implements NTF with complex zeros. $z_i = e^{\pm j\sqrt{g_1}}$
- ❑ For odd-order, use an integrator in the front to avoid noise coupling due to g .

CIFF with Resonators

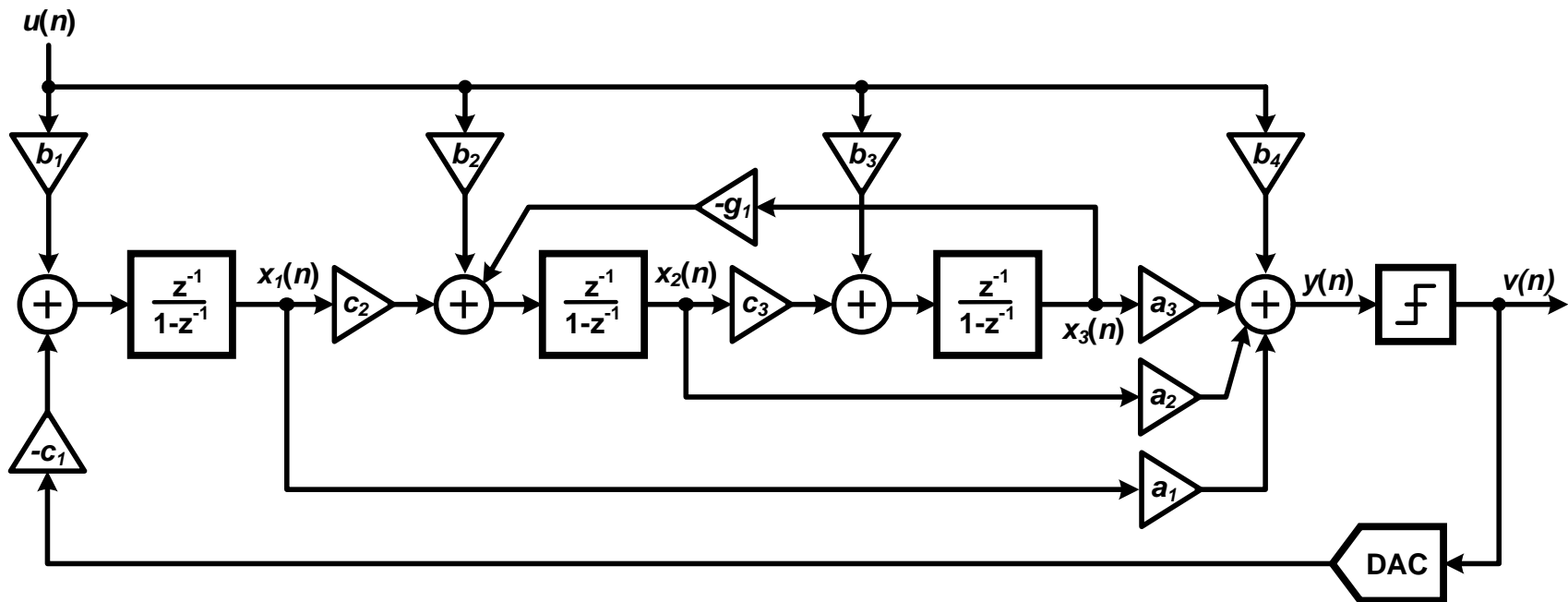

- Uses resonators formed with two delaying integrators.
 - ✓ Resonator poles outside the unit circle. $z_i = e^{1 \pm j\sqrt{g_1}}$

Low-Distortion CIFF Topology

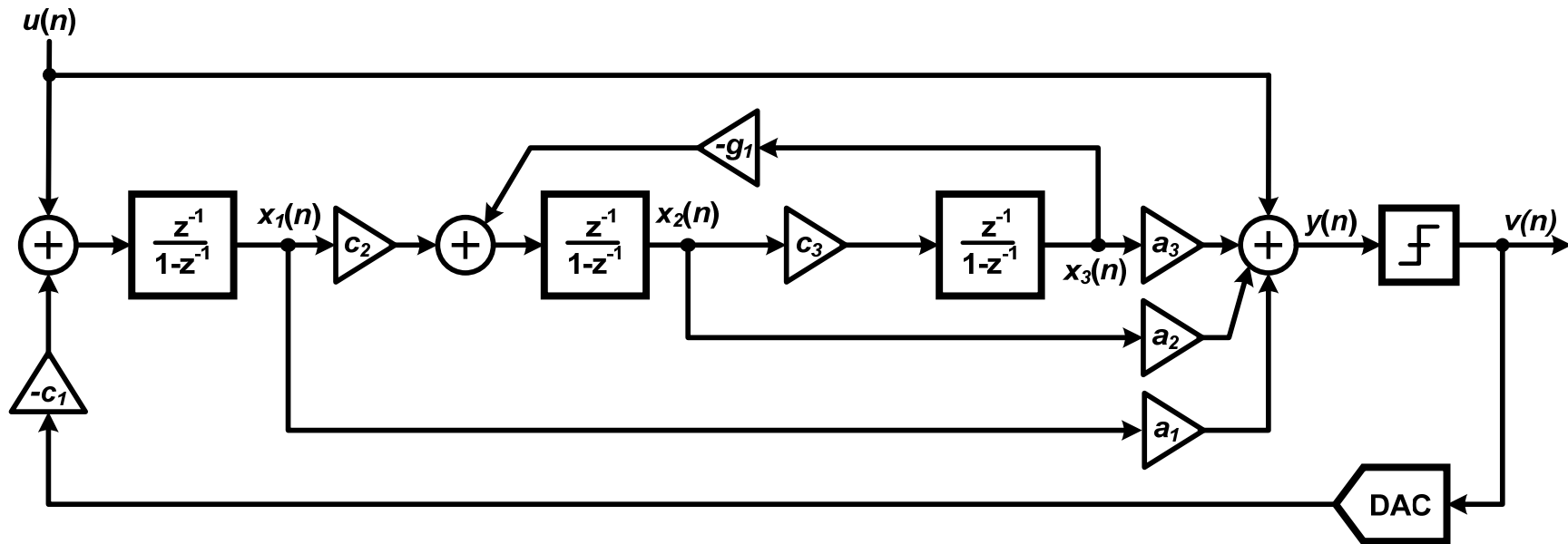

$$b_1 = b_{N+1} = 1$$

$$STF(z) = 1$$

MODULATOR MODEL DETAILS

A delta-sigma modulator with a single quantizer is assumed to consist of quantizer connected to a loop filter as shown in the diagram below.

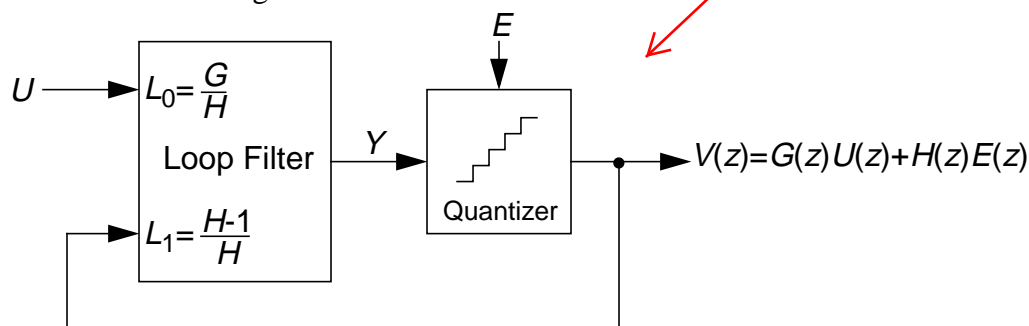

From the Delta-Sigma Toolbox Manual

The Loop Filter

The loop filter is described by an ABCD matrix. For single-quantizer systems, the loop filter is a two-input, one-output linear system and ABCD is an $(n+1) \times (n+2)$ matrix, partitioned into A ($n \times n$), B ($n \times 2$), C ($1 \times n$) and D (1×2) sub-matrices as shown below:

$$ABCD = \begin{bmatrix} A & B \\ C & D \end{bmatrix}. \quad (1)$$

The equations for updating the state and computing the output of the loop filter are

$$\begin{aligned} x(n+1) &= Ax(n) + B \begin{bmatrix} u(n) \\ v(n) \end{bmatrix} \\ y(n) &= Cx(n) + D \begin{bmatrix} u(n) \\ v(n) \end{bmatrix}. \end{aligned} \quad (2)$$

This formulation is sufficiently general to encompass all single-quantizer modulators which employ linear loop filters. The toolbox currently supports translation to/from an ABCD description and coefficients for the following topologies:

CIFB	Cascade-of-integrators, feedback form.
CIFF	Cascade-of-integrators, feedforward form.
CRFB	Cascade-of-resonators, feedback form.
CRFF	Cascade-of-resonators, feedforward form.
CRFBD	Cascade-of-resonators, feedback form, delaying quantizer.
CRFFD	Cascade-of-resonators, feedforward form, delaying quantizer

Multi-input and multi-quantizer systems can also be described with an ABCD matrix and Eq. (2) will still apply. For an n_i -input, n_o -output modulator, the dimensions of the sub-matrices are A : $n \times n$, B : $n \times (n_i + n_o)$, C : $n_o \times n$ and D : $n_o \times (n_i + n_o)$.

CIFB Structure

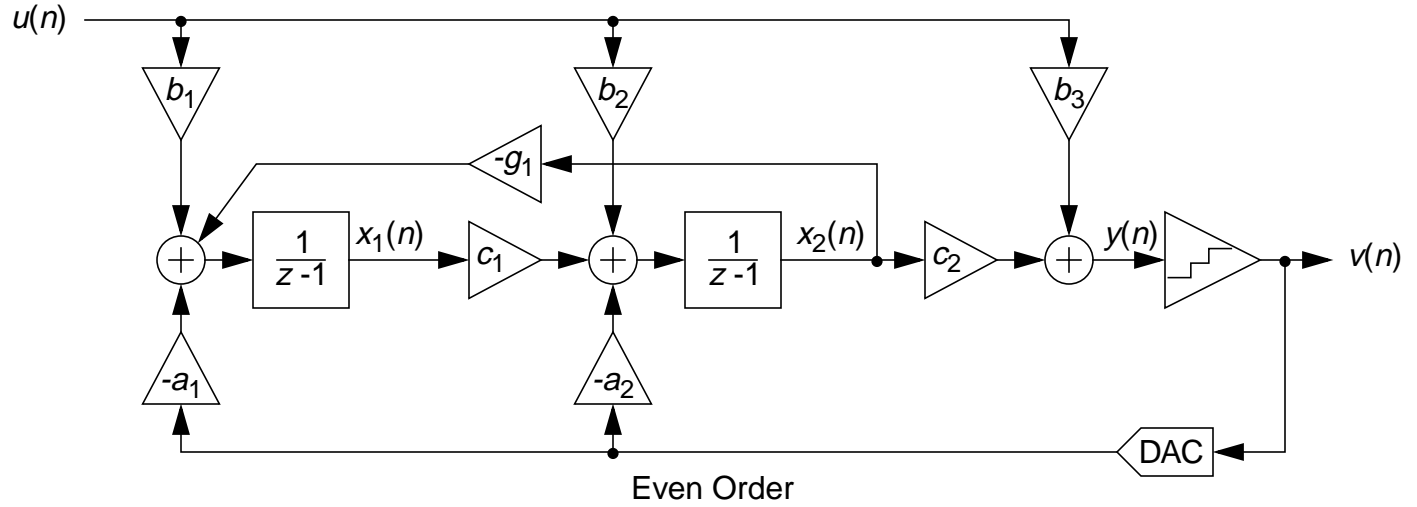

Even Order

For odd order, first integrator is not paired up as a resonator.

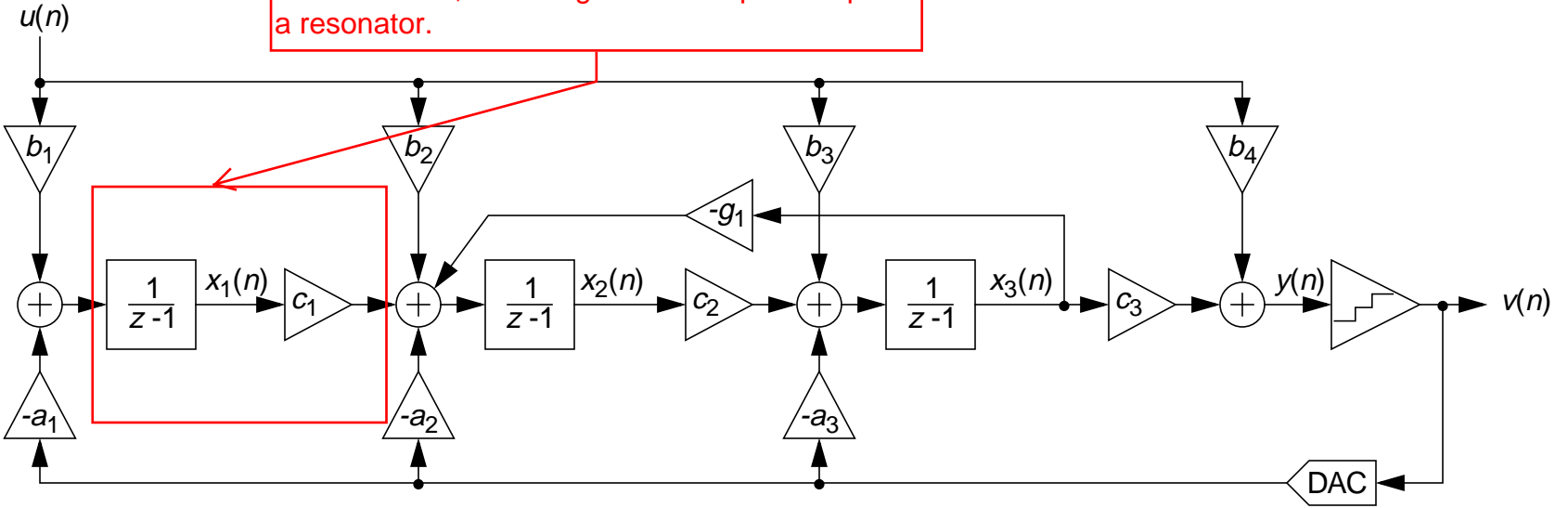

Odd Order

CIFF Structure

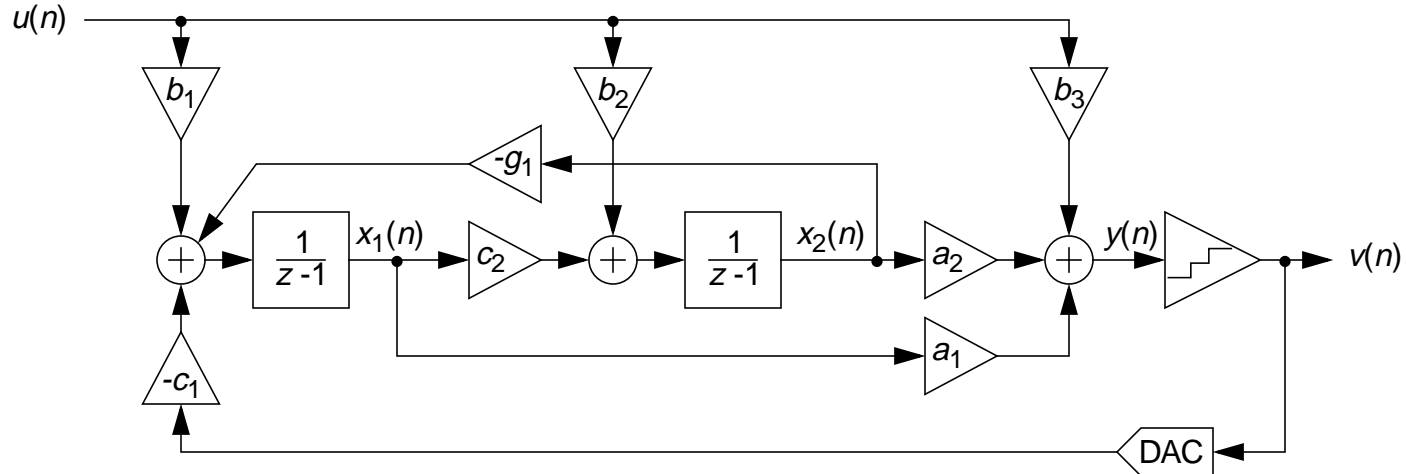

Even Order

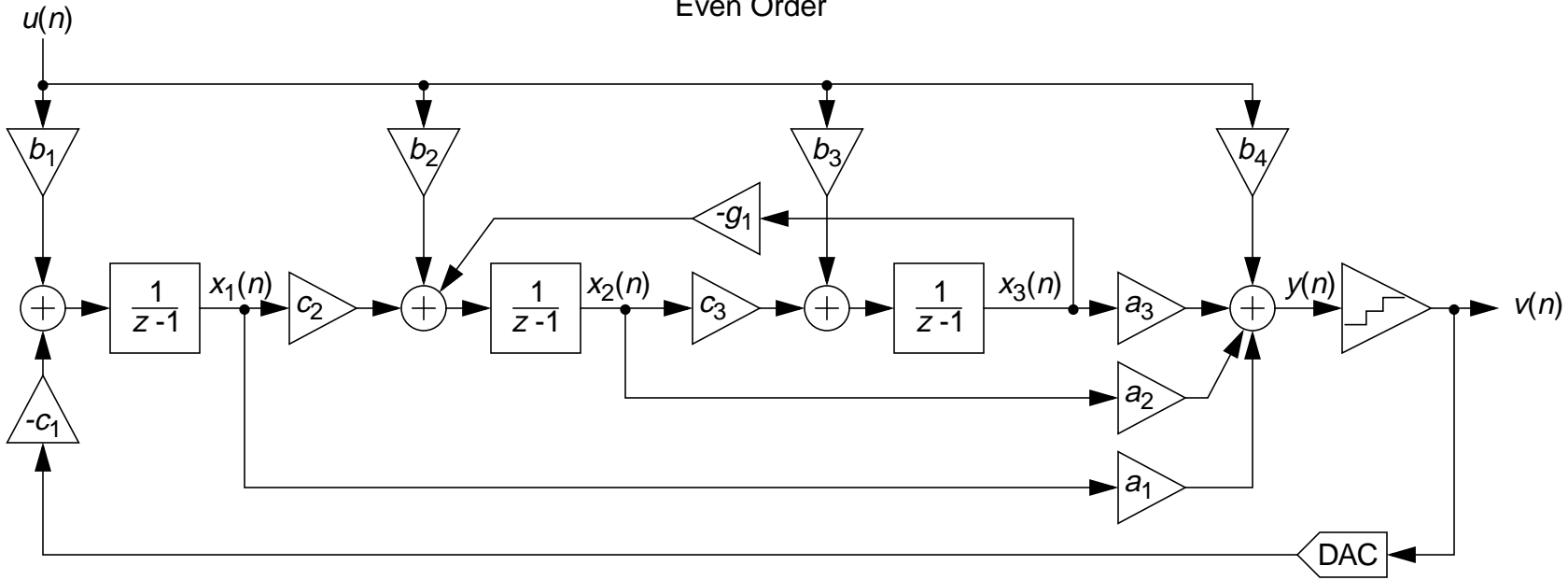

Odd Order

CRFB Structure

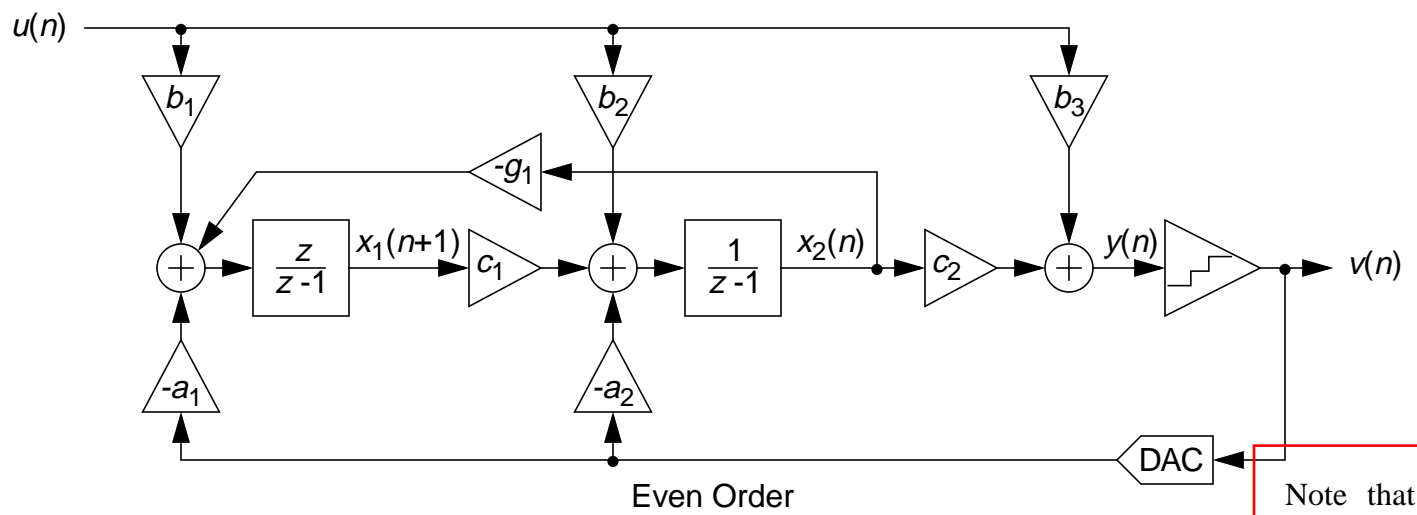

Note that with NTFs designed using `synthesizeNTF`, omission of the $b_2 \dots$ coefficients in the CRFB structure will yield a maximally-flat STF.

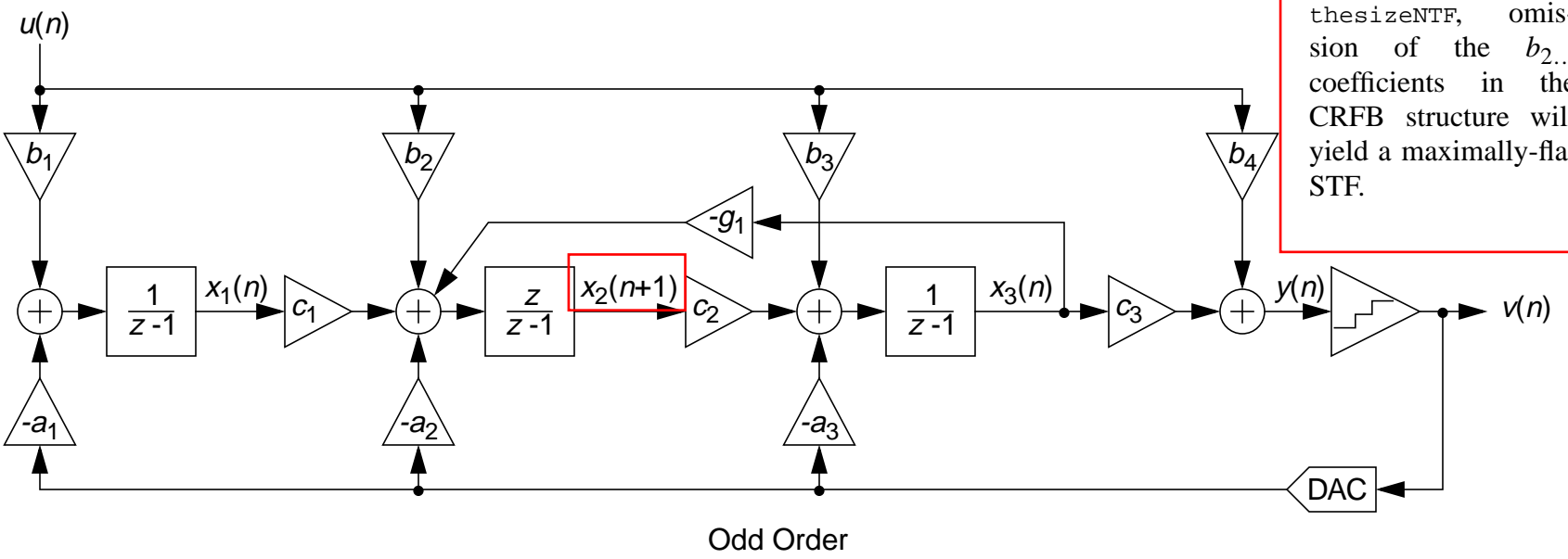

CRFF Structure

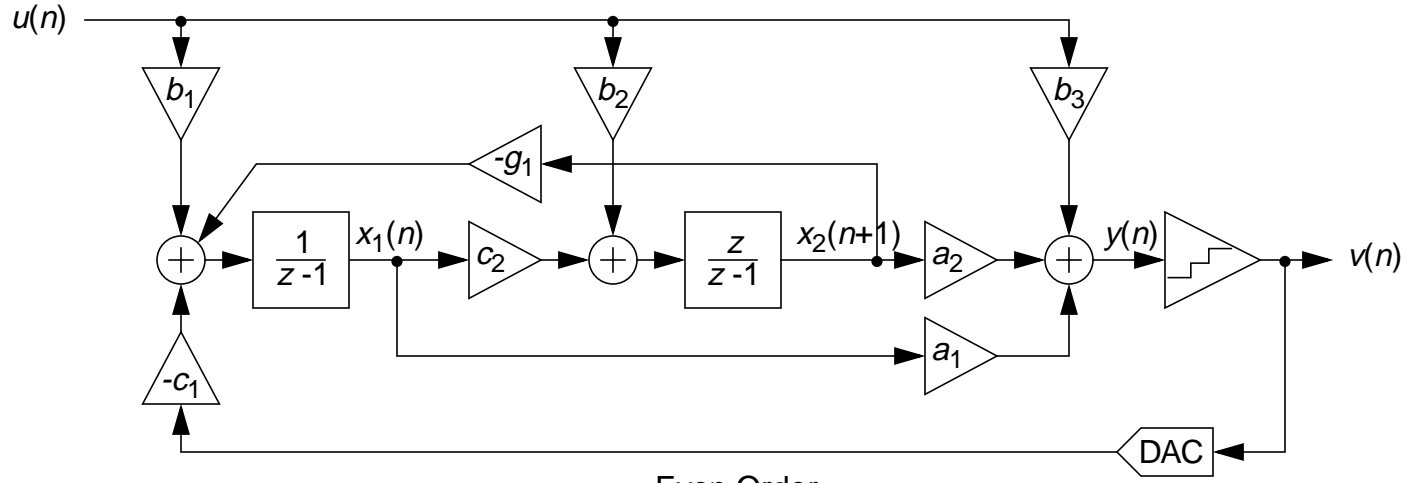

Even Order

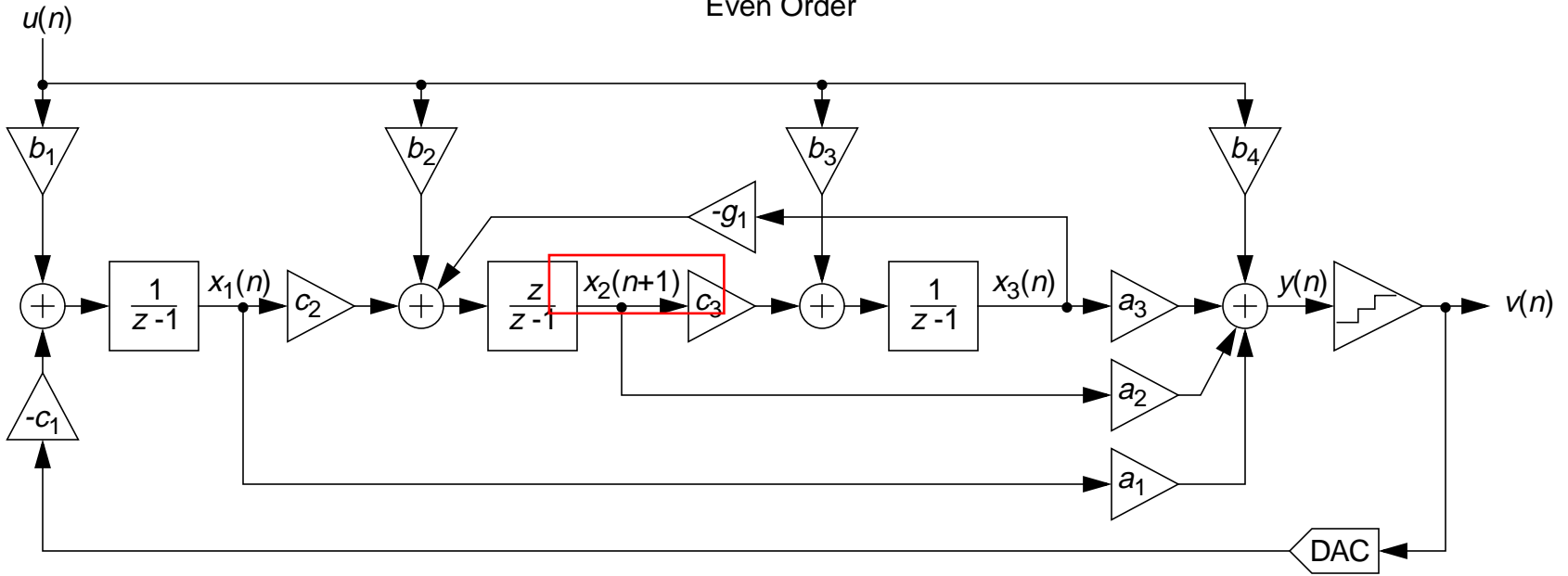

Odd Order

CRFBD Structure

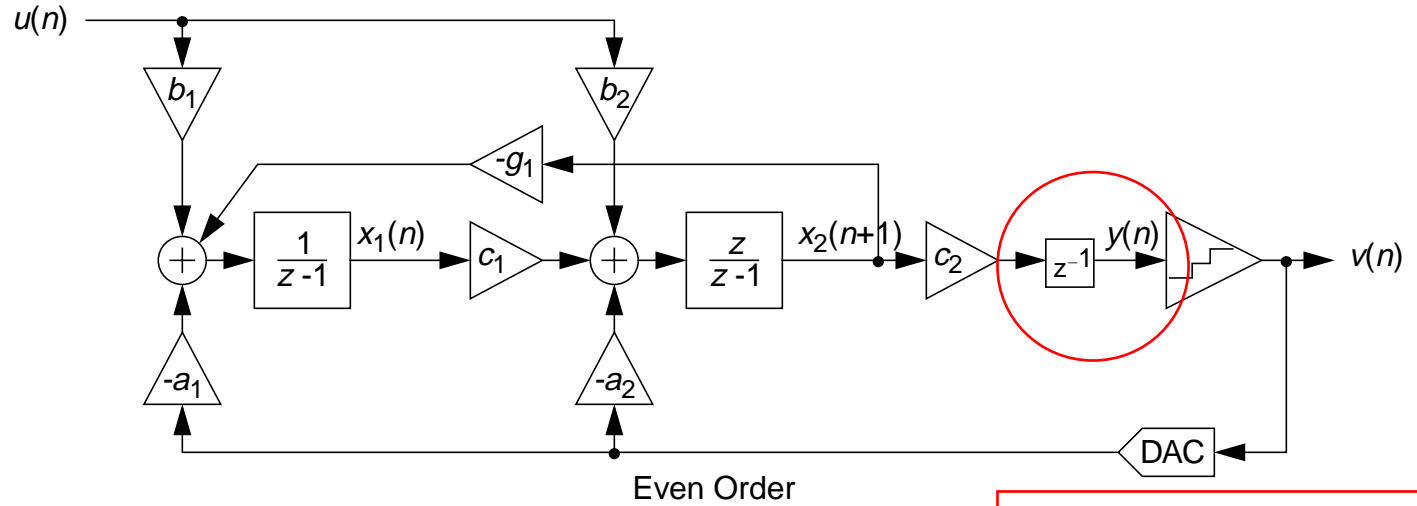

Even Order

b_{n+1} is not shown since it would have to be added to the quantizer input without delay, which is presumed to not be allowed in this structure. Note that this makes it impossible to have a unity STF.

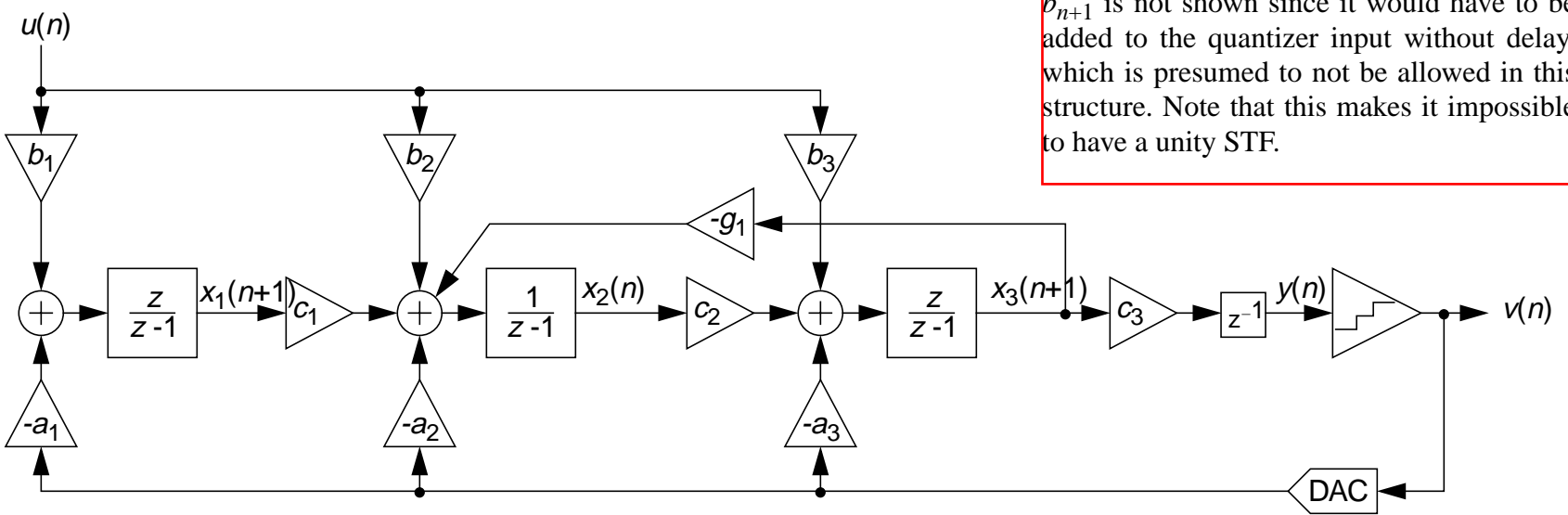

Odd Order

CRFFD Structure

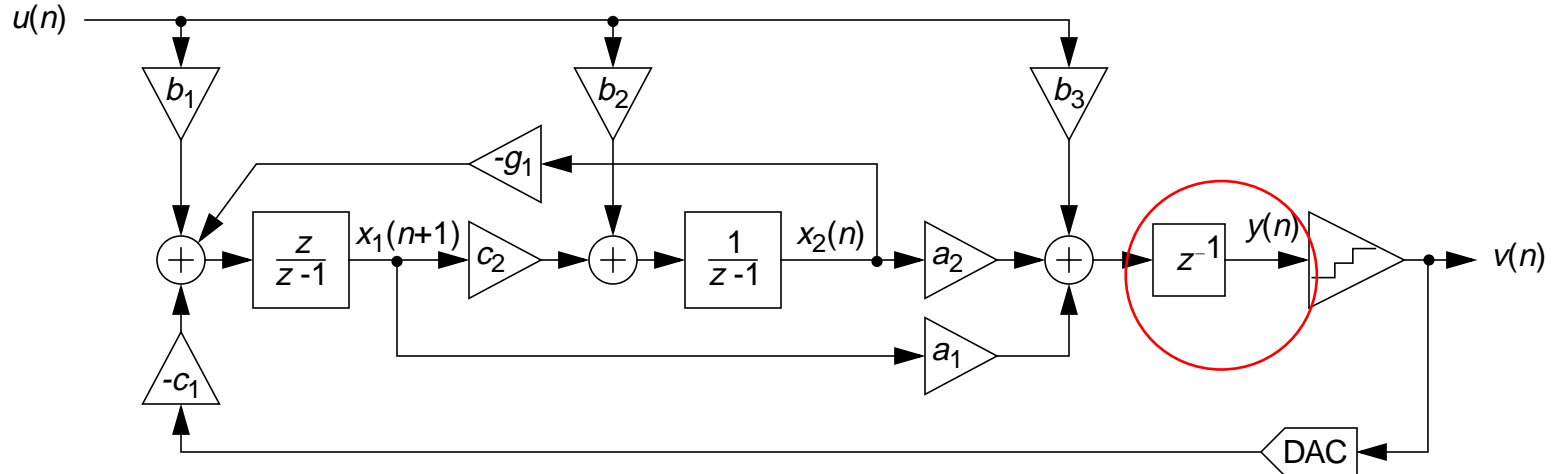

Even Order

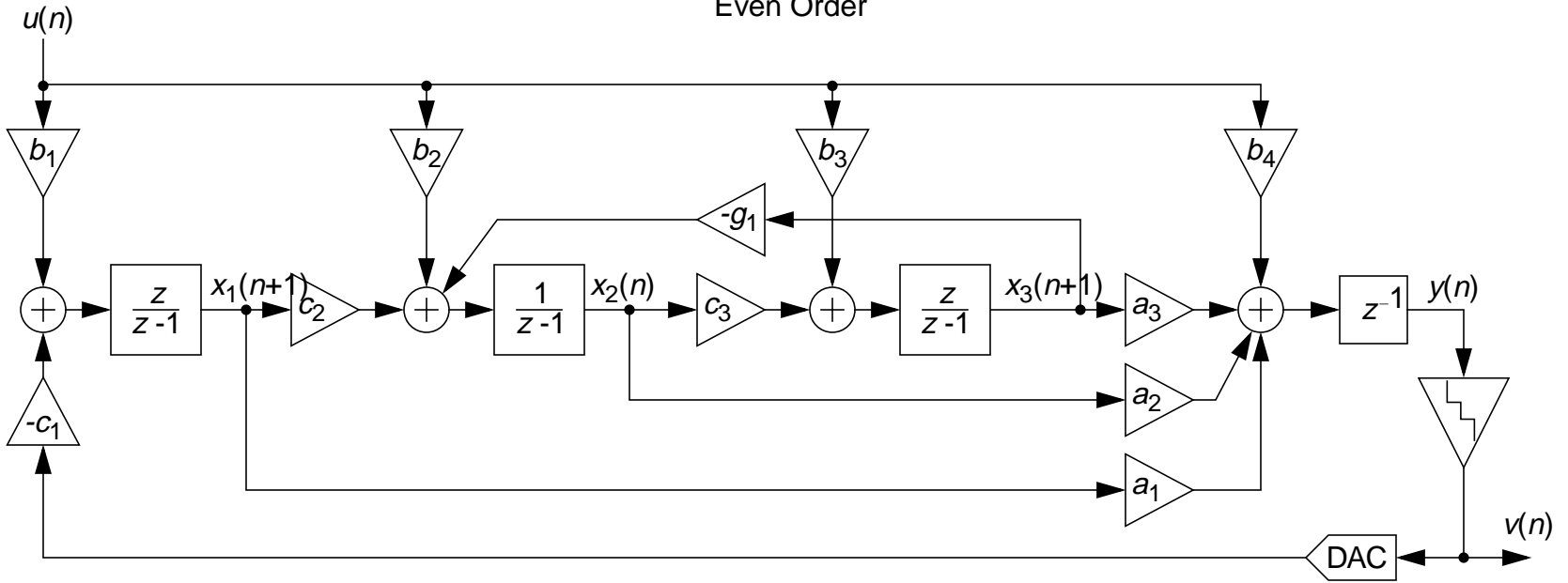

Odd Order