

The Electrical Effects of DNA as the Gate Electrode of MOS transistors

M. W. Dashiell¹, A. T. Kalambur², R. Leeson¹, K.J. Roe¹, J. F. Rabolt², and J. Kolodzey¹

¹Department of Electrical and Computer Engineering, University of Delaware, Newark, DE
19716

²Department of Materials Science and Engineering, University of Delaware, Newark, DE
19716

Correspondence should be addressed to J. Kolodzey (email: kolodzey@ee.udel.edu)

Abstract

The gate conductor material affects the threshold voltage of metal-oxide-semiconductor (MOS) transistors through the influence of the electrochemical work function and electric charge. Measurements of the threshold voltage from current voltage characteristics may therefore provide a method to estimate the electronic properties of biomolecules located on the gate electrode. We have deposited DNA from the corn genome onto the gate oxide of Si nMOS transistors and measured the effects on the current-voltage characteristics. We found that the DNA decreased the drain-source current compared to devices with clean gate oxides and pure buffer solutions. The threshold voltage was extracted by current-voltage measurements in the linear operating region and was found to increase by +1.9 volts after application of the DNA specimen, a value consistent with the expected negative charge density. This large change suggests that MOS devices may be useful as sensitive bioelectronic detectors.

Introduction

Currently there is interest in the development of high-speed, integrated techniques for rapid processing of biologically important molecules and neurological cells [1-3]. The industrial maturity of high-speed and high-density CMOS technology makes the silicon field effect transistor (FET) a natural contender for applications in this relatively new field. The purpose of our investigation was to analyze the response of Si FETs to the presence of DNA samples suspended in solution, which is placed directly upon the transistor gate oxide. The DNA-solution acts as the transistor gate electrode, replacing the conventional metal electrode

which is anticipated to interfere with direct coupling of the bio-material with the Si channel [4]. Figure 1 shows the conceptual design of our bio-FET design. Our approach was to measure the transistor characteristics and to extract device parameters including the threshold voltage, which depends on the electrochemical work function and electric charge of the DNA sample. We offer preliminary results illustrating the effects of biomolecular modification of the gate area on the transistor characteristics. We provide support that further investigation is warranted if this effect can be reliably used as a rational basis for detecting biomolecule specificity.

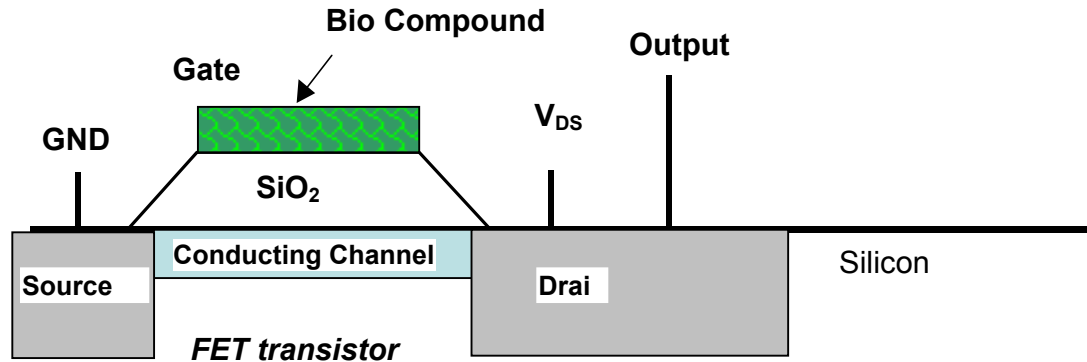

Figure 1. Cross sectional illustration of the bio-transistor with a biocompound (e.g. DNA) deposited on the gate oxide. The purpose of this device is to measure the effect of biological molecules and compounds located near the gate dielectric on the transistor characteristics. Electrode designations: GND (ground), V_{DS} (drain voltage).

Experimental

N-MOS transistors were fabricated starting with 1-10 Ω -cm p-type Si substrates and using a standard planar N-channel enhancement MOSFET process. Source and Drain regions were formed via phosphorus diffusion through a pre-patterned 500nm thick SiO_2 diffusion mask (bubbling O_2 carrier gas through POCl_3 for pre-deposition, followed by drive-in in an N_2 ambient). The gate insulator was formed by dry-oxidation involving bubbling high purity O_2 gas through semiconductor grade TCE forming a 50nm thick SiO_2 gate insulator. The biosensor FETs had an active area of 50 x 200 (lengthxwidth) square micrometers and the gate oxide capacitance per unit area was: $C_{OX} = 69\text{nFcm}^{-2}$.

During this work we used single stranded DNA (a 20 base oligomer, from Synthetic Genetics) in a phosphate buffer solution with a pH of 7. The DNA-solution and the reference material (buffer without DNA) were applied with a dropper on the gate insulator during electrical testing. We measured the current-voltage (I-V) characteristics of equivalent transistor structures with floating gates prior to application of solution and also for gate

electrode consisting of the phosphate buffer only and the DNA suspended within the buffer. Figure 2 shows the I-V curves of the transistor (i) prior to application of solution (ii) after application of the phosphate buffer solution, (iii) after application of the DNA in the buffer solution and (iv) after the DNA solution remained on the gate for 3 hours. It is immediately obvious that the drain to source current changes significantly for equivalent driving voltages (V_{DS}) after application of the buffer and DNA/buffer solutions. We observed that the transistor characteristics were not stable with time for both the buffer solutions and the DNA solutions, an effect which has also been observed for neurological cells suspended in an electrolyte solution on the gates of p-channel Si FETs-probably due to chemical interaction between the SiO_2 insulator and ions within the buffer solution[4]. It has been suggested that a silicon nitride cap on the gate and use of n-type Si will alleviate the problem of ionic diffusion from the buffer solution into the Si/ SiO_2 interface region.

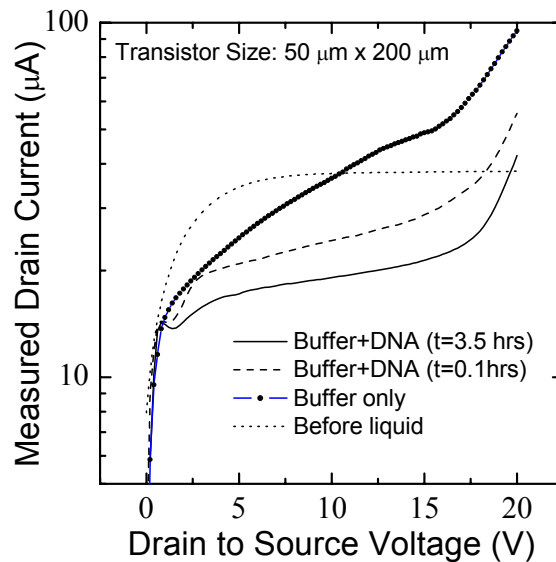

Figure 2. The current-voltage characteristics of biosensor transistor fabricated using silicon MOS circuit technology. The data show the drain-to-source current I_{DS} versus the drain-to-source voltage V_{DS} , for different gate conditions including the presence of DNA. No external bias was applied to the gate, and the substrate was grounded ($V=0$). The variations in current traces may indicate differences in the electrochemical potentials of the gate molecules. A solution of DNA decreased the output current by 20 μA compared to the buffer solution, indicating that the DNA had a negative charge.

Effect of gate-electrode (DNA) on the FET threshold voltage

The threshold voltage (V_T) is an important figure of merit for Si FETs which dependent on Si doping, oxide thickness, the electrochemical work function of the gate electrode, and the charges in the vicinity of the Si/SiO₂ interface. V_T can be extracted from the transistor IV characteristics, operating in the linear region, by the following well known equation for drain current:

$$I_D = (\beta_n/2)[2(V_G - V_T)V_D - V_D^2] \quad (1)$$

Our experiments indicated that DNA shifted the threshold voltage parameter (V_T) by about + 1.92 volts compared to that of the FET using the buffer solution alone as gate electrode. The experimental I-V and curve fit using equation (1) are shown in figure 3. Such large threshold shifts indicated a strong sensitivity to DNA, and the positive direction (less negative) corroborated the well known negative charge of DNA molecules. Table I summarizes the result of the V_T extraction for several gate electrode conditions and with a grounded substrate.

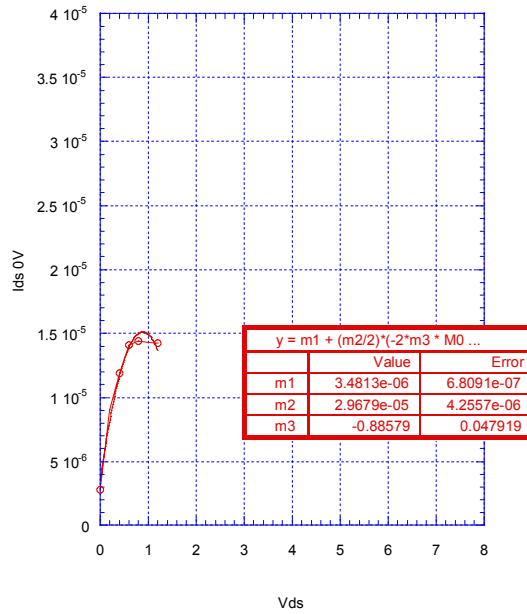

Figure 3. Curve fit of the transistor I-V in the linear operating region to equation (1).

The measured V_T shift corresponded to a net negative charge Q per area which we attribute to the addition of DNA into the buffer solution:

$$Q = CV = (69\text{nF}\cdot\text{cm}^{-2}) \times (-1.92\text{V}) = -(1.3 \times 10^{-7} \text{Coulomb}\cdot\text{cm}^{-2}). \quad (2)$$

This value of charge density reasonably agrees (within one order of magnitude) with that of DNA, which is reported in the micro-Coulomb range [5].

Data for the threshold voltage, V_{T0} , with zero substrate bias, are summarized in Table 1. It is important to note that the phosphate buffer solution itself strongly affects the transistor characteristics, even more so than the effect of the DNA. It is not clear yet if the strong change in threshold voltage after application of the buffer is due solely to its electrochemical potential, or if there is also diffusion of charged ions from the buffer solution into the SiO_2 . We believe that phosphate buffer solution itself affects the integrity of the oxide insulator; this is supported from our observation that the V_T does not return to its value prior to application of the buffer, even after thorough washing and rinsing in DI water and that the transistor characteristics are not stable over periods of time (hours). This effect was also observed in the work of reference [4] for neurological cells suspended in an electrolytic solution.

Table 1. Table of extracted threshold voltages using the curve fitting technique described in the text.

Gate Condition	V_{T0}
Clean gate oxide	-6.57 V
oxide with buffer solution	-2.81 V
with DNA+buffer	-0.89 V
DNA+buffer (3.5 Hours Later)	-0.80 V
DNA+buffer (3 Days Later)	-3.36 V
Cleaned (4 Days Later)	-5.15 V

Conclusions

We have found that DNA molecules suspended in solution placed on the gate insulator produce a significant shift in the threshold voltage. This effect may be usable for bioelectronic device applications such as sensing and identification. Future work involves developing an optimized process in which the degradation effects of the buffer solution are eliminated or at least completely understood, so that any effect of charged ion interactions with the SiO_2 insulator can be taken into account in the analysis. The second optimization must focus on understanding the adherence of the DNA molecules onto the SiO_2 gate insulator. We anticipate that the most sensitive Bio-FET detector will require direct adhesion of the DNA molecules onto the gate electrode rather than being randomly suspended with solution

In conclusion we designed, built and tested a novel prototype biomolecular- sensitive FET transistor that varies its output current in response to the presence of DNA on its gate

electrode. Our electrochemical potential biosensor transistor was fabricated using standard MOS processing. The array density of these sensor transistors can be equivalent to the densities of transistors in integrated circuits: above 10^7 cm⁻². The bio-electrochemical sensor transistors may be capable of yielding the time dependent behavior of bio-molecules, and could be used to explore the possibilities of semiconductor-biological hybrid circuits. Possible applications include sensing and identifying proteins and DNA.

Research sponsored by NSF under SGER grant ECS-0129535

References

- [1] L. Richard Huang, Jonas O. Tegenfeld, Jessica J. Kraeft, James C. Sturm, Robert H. Austin and Edward C. Cox, "Generation of Large-area Tunable Uniform Electric Fields in Microfluidic Arrays for Rapid DNA separation", IEDM Proceedings, pp. 363-366, 2001.
- [2] Peter Fromherz, "Microelectronics meets Molecular and Neurobiology", IEDM proceedings, pp. 355-358, 2001.
- [3] C.A. Mirkin and T.A. Taton, "Semiconductors Meet Biology," *Nature*, Vol. 405, pp. 626-627.
- [4] Peter Fromherz, Andreas Offenhausser, Thomas Vetter, Jurgen Weis, "A Neuron-Silicon Junction: A Retzius Cell of the Leech on an Insulated-Gate Field-Effect Transistor", *Science*, vol. 252, pp. 1290-1292, 1991.
- [5] B. J. Yoon and A. M. Lenhoff, "Computation of the Electrostatic Interaction Energy between a Protein and a Charged Surface," *J. Phys. Chem.*, vol. 96, pp. 3130-3134, 1992.