

# PV System Components

- Key issues in components:
  - Power loss in each component
  - Implications of component on maintenance, lifetime of PV system
  - Matching of components
  - How addition of component affects system cost
- PV System components:
  - PV Modules
  - Batteries
  - Power Conditioning
  - Loads
  - Balance of systems

# Batteries

- Batteries required if (1) load profile  $\neq$  solar radiation profile and (2) to mitigate effect of variability in sunshine.
- Batteries have a major impact of PV system performance: They alter maintenance, design, are a large fraction of cost, reliability & aging, safety.
- Key issues in batteries:
  - Why and how battery voltage and capacity change with system and battery parameters.
  - Operating constraints on batteries: constraints of state-of-charge, discharge/charge rate, temperature.
  - Lifetime and safety issues with batteries

- Outline
  - Battery basics:
    - Chemical redox reactions
    - Components of a battery
    - Equilibrium voltage: calculation using Nernst Equation
    - Ideal battery capacity: calculations
    - Non-equilibrium voltage and capacity: Effect of reaction rates
      - Polarization: Activation, Mass Transport, Resistive
      - Effect of charging, discharging, aging
    - Time-dependent effects in batteries: aging
    - General safety issues in batteries

- Outline
  - Battery Characteristics
    - Charging and discharging parameters: BSOC, DOD, discharge rate
    - Capacity
    - Efficiency
    - Energy, volumetric and power density
    - Other electrical parameters
  - Lead Acid Batteries
    - Operation of lead acid batteries: Chemical reactions
    - Lead acid battery characteristics
    - Issues specific to lead acid batteries
    - Potential problems with lead acid batteries

- Outline
  - Lead Acid Batteries Configurations
    - Electrode materials: addition of small amount of other substances affects gassing, charging, sulfation, etc
    - Electrolyte: Gelled or AGM batteries
    - Battery housing: flooded, sealed, valve-regulated
    - Types of lead-acid batteries
  - Other battery systems: nickel cadmium

# PERIODINĖ CHEMINIŲ ELEMENTŲ SISTEMA

IA 1																	VIIIA 18		
1 1 H 1,01 Vandenilis																	2 2 He 4,00 Helis		
2 3 Li 6,94 Litis	IIA 2 4 Be 9,01 Berilis											IIIA 13 5 B 10,81 Boras	IVA 14 6 C 12,01 Anglis	VA 15 7 N 14,01 Azotas	VIA 16 8 O 16,00 Deguonis	VIIA 17 9 F 19,00 Fluoras	10 Ne 20,18 Neonas		
3 11 Na 22,99 Natriis	12 Mg 24,30 Magnis	IIIB 3 21 Sc 44,96 Skandis	IVB 4 22 Ti 47,88 Titanas	VB 5 23 V 50,94 Vanadis	VIB 6 24 Cr 51,94 Cromas	VIIA 7 25 Mn 54,94 Manganas	VIIIB 8 26 Fe 55,85 Geležis	VIIIB 9 27 Co 58,93 Kobaltas	VIII 10 28 Ni 58,69 Nikelis	IB 11 29 Cu 63,55 Varis	IIB 12 30 Zn 65,39 Cinkas	31 Ga 69,72 Galis	32 Ge 72,61 Germanis	33 As 74,92 Arsenas	34 Se 78,96 Selenas	35 Br 79,90 Bromas	36 Kr 83,80 Kriptonas		
4 19 K 39,10 Kalis	20 Ca 40,09 Kalcis	37 Rb 85,47 Rubidis	38 Sr 87,62 Stoncis	39 Y 89,91 Skandis	40 Zr 91,22 Cirkonis	41 Nb 92,91 Niobis	42 Mo 95,94 Molibdenas	43 Tc (97,90) Technecis	44 Ru 101,07 Rutenis	45 Rh 102,91 Rodis	46 Pd 106,42 Paladis	47 Ag 107,87 Sidabras	48 Cd 112,41 Kadmis	49 In 114,82 Indis	50 Sn 118,71 Alavas	51 Sb 121,75 Stibis	52 Te 127,60 Telūras	53 I 126,90 Jodas	54 Xe 131,29 Ksenonas
5 37 Rb 85,47 Rubidis	38 Sr 87,62 Stoncis	55 Cs 132,90 Cezis	56 Ba 137,33 Baris	72 Hf 178,49 Hafnis	73 Ta 180,95 Tantalas	74 W 183,85 Volframas	75 Re 186,21 Renis	76 Os 190,2 Osmis	77 Ir 192,22 Iridis	78 Pt 195,08 Platina	79 Au 196,97 Aukzas	80 Hg 200,59 Gvysidabris	81 Tl 204,38 Talis	82 Pb 207,2 Švinas	83 Bi 208,98 Bismutas	84 Po (208,98) Polonis	85 At (209,99) Astatis	86 Rn (222,02) Radonas	
6 55 Cs 132,90 Cezis	56 Ba 137,33 Baris	87 Fr (223,02) Francis	88 Ra (226,02) Radis	104 Rf (261,1) Rezerfordis	105 Db (262) Dubnis	106 Sg (263) Syborgis	107 Bh (264) Boris	108 Hs (265) Hasis	109 Mt (266) Meitneris	110 Uun (267) Uun									
7 87 Fr (223,02) Francis	88 Ra (226,02) Radis																		

Atomo numeris  
Elementų klasifikacija  
(■ - metalas,  
□ - nemetalas,  
◻ - pusmetalis)

13 ■ +3  
Al  
26,98  
Aluminis

Oksidacijos laipsnis  
Simbolis  
Santykinė atominė masė  
Pavadinimas

Universaliaji dujų konstanta  
R = 8,31447 J mol<sup>-1</sup> K<sup>-1</sup>  
Avogadro skaičius  
N = 6,022137 · 10<sup>23</sup> mol<sup>-1</sup>  
Faradėjaus skaičius  
F = 96485,31 C/mol

Lantanoidai

6

Aktinoidai

7

57 ■ +3 La 138,91 Lantanas	58 ■ +3 +4 Ce 140,11 Ceris	59 ■ +3 +4 Pr 140,91 Pražėodimis	60 ■ +3 Nd 144,24 Neodimis	61 ■ +3 Pm (144,91) Prometis	62 ■ +2 +3 Sm 150,36 Samaris	63 ■ +2 +3 Eu 151,96 Europis	64 ■ +3 Gd 157,25 Gadolinis	65 ■ +3 +4 Tb 158,92 Terbis	66 ■ +3 Dy 162,50 Disprozis	67 ■ +3 Ho 164,93 Holmis	68 ■ +3 Er 167,26 Erbis	69 ■ +3 Tm 168,93 Tulis	70 ■ +2 +3 Yb 173,04 Iterbis	71 ■ +3 Lu 174,97 Liutecis
89 ■ +3 Ac (227,03) Aktinis	90 ■ +4 Th 232,04 Toris	91 ■ +4 +5 Pa (231,04) Protaktinis	92 ■ +3 +4 +5 +6 U 238,03 Uranas	93 ■ +3 +4 +5 +6 +7 Np (237,05) Neptunis	94 ■ +3 +4 +5 +6 Pu (244,06) Plutonis	95 ■ +3 +4 +5 +6 Am (243,06) Americis	96 ■ +3 +4 Cm (247,07) Kiuris	97 ■ +2 +3 +4 Bk (247,07) Berklis	98 ■ +2 +3 +4 Cf (251,08) Kalifornis	99 ■ +2 +3 Es (252,08) Einšteinis	100 ■ +2 +3 Fm (257,09) Fermis	101 ■ +2 +3 Md (258,10) Mendelevis	102 ■ +2 +3 No (259,1) Nobelis	103 ■ +3 Lr (260,1) Laurensis

# Chemistry Basics

- Mols, molar mass
- Molarity
- Balancing chemical equations

# Oxidation/Reduction Reactions



- Basis for battery systems is an oxidation/reduction reaction.
- In an oxidation reaction, the valence state of a material(s) in the reaction increases, producing extra electrons.
- In a reduction reaction, valence state of elements are reduced, using extra electrons.
- A reduction/oxidation reaction must be paired, and is called a redox reaction.
- A redox reaction involves the transfer of electrons from one reaction to another – usually the reactions take place in close proximity to one another.

# Battery basics

- Battery: Redox (reduction oxidation) reaction, physically separated.
- Overview: Oxidation reaction generates an electron surface of electrode; electron transported to cathode, ion in electrolyte transported to anode; voltage generated by chemical potential between the anode and cathode.
- Components:
  - Electrode (cathode, anode),
  - Electrolyte
  - Electron transport (wire)
  - Ion transport (electrolyte)
  - Housing, etc for battery

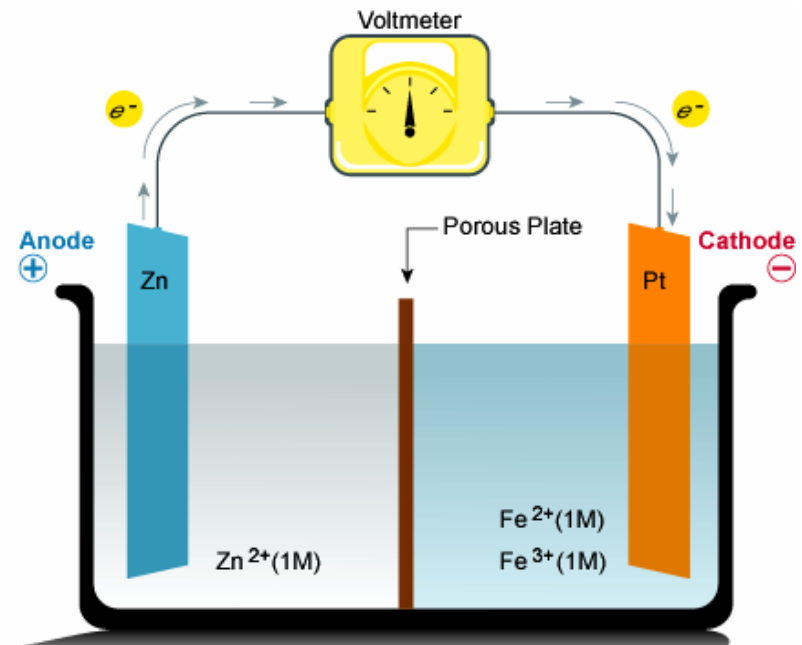

# Batteries

- A primary battery is one which cannot be recharged; a secondary battery can be recharged.
- The anode and cathode of the battery refer to where the oxidation and reduction reactions take place (when discharging). Collectively, they are the electrodes.
- Need to make electrical contact to the anode and cathode
- Solution surrounding electrodes is electrolyte
- Need to provide conductive medium for transport of ions: conceptually use salt bridge, but in practical batteries use identical electrolyte for both half reactions.

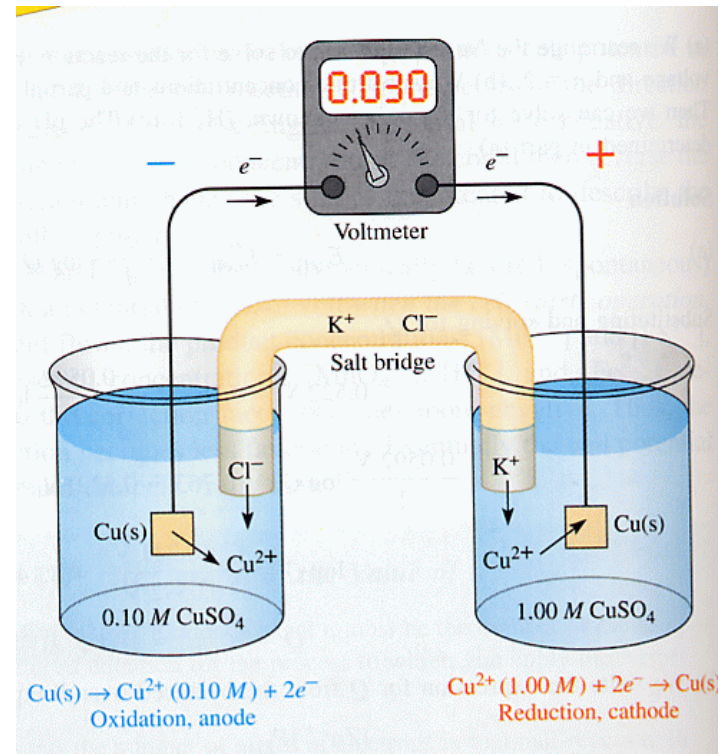

# Redox Reactions

- Redox reactions are reduction/oxidation pairs (each called a half-reaction), and involve transfer of electrons between the two reactions.
- Electrons are due to a change in the valence state of a materials in the redox reaction.

- Reduction reaction: Uses an electron to reduce valence state of a material:

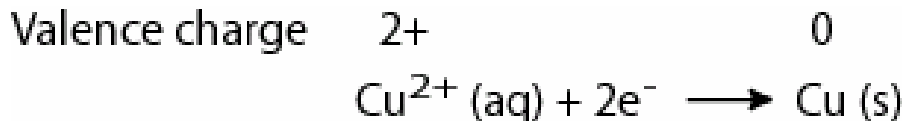

- Oxidation reaction: Produces an electron; valence state increases.

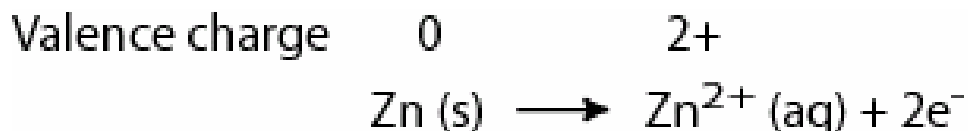

- Overall redox reaction:

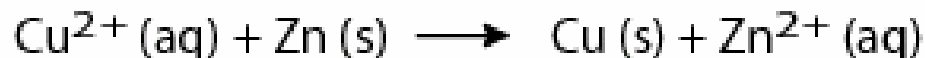

# Oxidation/Reduction Reactions



- Examples:

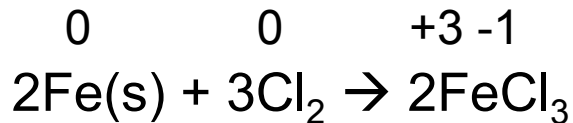

Fe is reducing agent and gets oxidized

Cl is the oxidizing agent, and gets reduced

- Example: balance and identify elements that are oxidized and reduced



- Often helps to separately write oxidation and reduction (half cell reactions)

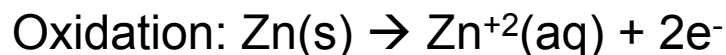

# Electrochemical Potential

- Electrochemical potential is a measure of the average energy of the valence states of a material – analogous to the Fermi-energy in semiconductors.
- Lowest energy state is a full valence band, consisting of 8 electrons in the outer shell.
  - Valence changes closer to this ideal state are spontaneous, and occur provided that either an electron is available, or the extra electron can be used by another material.
  - Spontaneous valence changes are defined as positive.

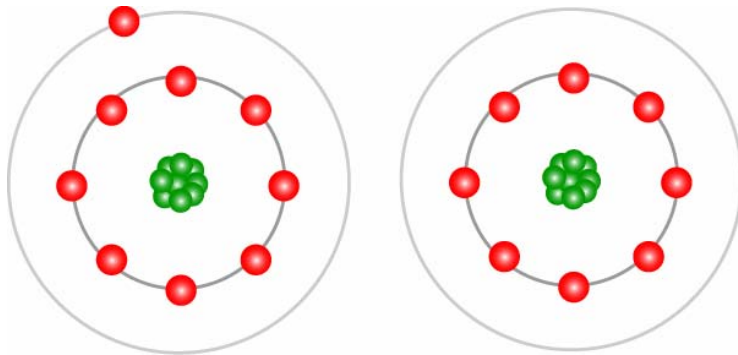

# Electrochemical Potential



- A material has a certain electrochemical potential which depends on the electronic configuration of the compound.
- In going from one form to another, the compound changes its electrochemical potential, dependant on the change in valence state of the compounds.
- We can measure the change in the electrochemical potential, and under standard conditions (25 °C, 1 M solutions, H<sub>2</sub> as the comparison), the change in electrochemical potential can be measured, as is given as a table.
  - Large positive numbers indicate a good acceptor of electrons: good oxidizing agent, it gets reduced.
  - Large negative numbers indicate good source of electrons good reducing agent, material itself gets oxidized.

# Electrochemical potential

- Table of standard electrochemical potentials give direction of spontaneous reaction and also give standard potential of a reaction.
- The standard potential of a reaction is the sum of the potentials for the two half reactions.
  - An overall positive standard potential will proceed spontaneously, a negative one will not.
  - Reversing the direction of the half reaction changes the sign of the reaction.
  - When combining half reactions into an overall reaction, the value of the standard potential is not altered by multiplicative constants for balancing.

# Electrochemical Potential

- Electrochemical potentials are typically written as reduction reactions
- If the reaction is inverted, then the sign on the electrochemical potential changes.

- For lithium, electrochemical potential is:



- Electrochemical reaction is sum of two half-reactions
- Example: for Zn and Cu, from a standard potential tables:

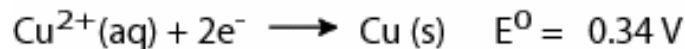

- Net reaction is:

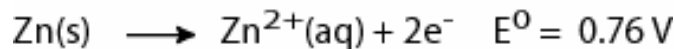

- Standard potential is 1.1 V

# Electrochemical potential

- Examples:

- Will the following reaction spontaneously occur?

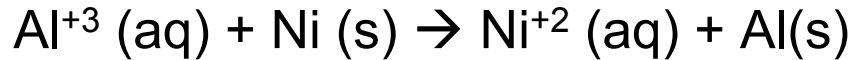

Total is -1.43V: reaction will NOT occur spontaneously

- What is potential of following reaction:



Total voltage is 0.33V

# How many electrons?

- We are interested in current of a battery, as well as its voltage, so need to determine the number of electrons required by a reaction.

- Faradays Law:

$$1 \text{ faraday} = 6.022 \times 10^{23} \text{ electrons} = 96,485 \text{ C}$$

- Example: Volume of O<sub>2</sub> gas produced by electrolysis of water

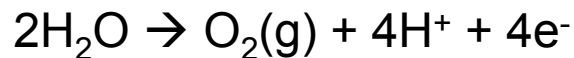

For 1 mol of O<sub>2</sub> need 4(96,485 C) = 386,000 C of electrons.

At standard pressure, 1 mol of gas = 22.4 liters, so get  $5.8 \times 10^{-5}$  liters per  
Coulomb

For 1 A of current will produce 1 C in 1 sec, so get  $5.8 \times 10^{-5}$  l/sec

# Nernst Equation

- The chemical potential from a set of reactions depends on the concentration in equilibrium of the product and the reactants.
- These dependencies are included in the Nernst Equation

$$E = E^0 - \frac{RT}{nF} \ln(Q) = E^0 - \frac{0.0592}{n} \log(Q)$$

R is gas constant, 8.314 J/(mol K)

T is temperature

F is faraday's constant

$E^0$  is the standard potential of the reaction

n is the moles of electrons transferred in the reaction.

Q is the reaction quotient

# Nernst Equation

- Nernst equation allows determination of the electrochemical potential under different temperatures, pressures or concentrations.

$$E = E^0 - \frac{RT}{nF} \ln Q \quad Q = \frac{[D]^d [C]^c}{[B]^b [A]^a}$$



- Battery capacity:

$$\text{Capacity (Ah)} = n \times F \times \frac{1 \text{ hour}}{3600 \text{ sec}}$$

$$\text{Energy Capacity} = \text{Ah} \times \text{Battery Voltage}$$

# Nernst Equation

- Reaction coefficient,  $Q$  depends on concentration of reactants and products. Pure liquids and solids are taken as 1. Liquids in solutions are given by their molarity (M), gasses by their pressure.
- Example: The copper-zinc cell has  $E^0 = 1.101$  V. If the reaction is done in a cell in 5.00 M  $Zn^{+2}$  and 0.30 M  $Cu^{+2}$  at 25 C, what is the cell voltage?

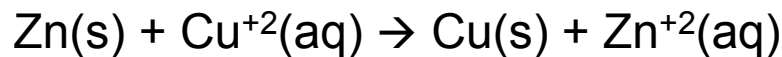

$$Q = \frac{[Zn^{+2}]}{[Cu^{+2}]} = Q = \frac{5.00}{0.30} = Q = 16.7$$

Two electrons are transferred, so  $n=2$ .

$$E = E^0 - \frac{0.0592}{n} \log(Q) = 1.101 - \frac{0.0592}{2} \log(16.7)$$

$$E = 1.065 \text{ V}$$

# Polarization

- Nernst equation calculates battery voltage at equilibrium; under non-equilibrium voltage is different due to polarization:
  - Activation overvoltage
  - Mass transport polarization
  - Resistive effects

- Over potential: need higher voltage to charge the battery than discharge the battery.
  - Resistive drops: voltage drop at all parts of the battery (including surfaces) causes higher voltage at terminals compared to battery
    - Non uniform resistances can cause uneven charging in series connected systems.
  - Geometrical/ diffusion effects involving surface:
    - The products and reactants need to diffuse towards the surface.
    - Local regions may locally have a different concentration, causing a different voltage.

# Non-ideal effects in batteries

- Over potential due to reversibility of reactions
  - Most reactions are not completely reversible due to the presence of intermediate products in the reactions.
  - The formation of an intermediate product may involve a higher energy state.
  - A fraction of the initial reactants will have this higher energy
  - For the reaction to go in reverse, need to apply higher potential.
  - Electrolysis of water has high overpotential

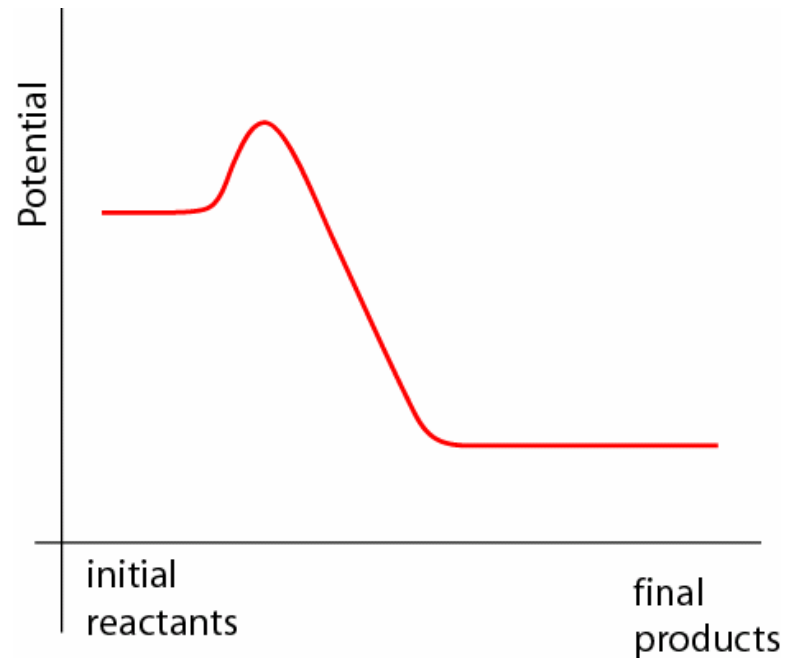

# Battery Systems

- Key characteristics of a battery:
  - Cost
  - Volumetric /Gravimetric energy density
  - Voltage
  - Charging regimes
  - Efficiency
  - Depth of discharge

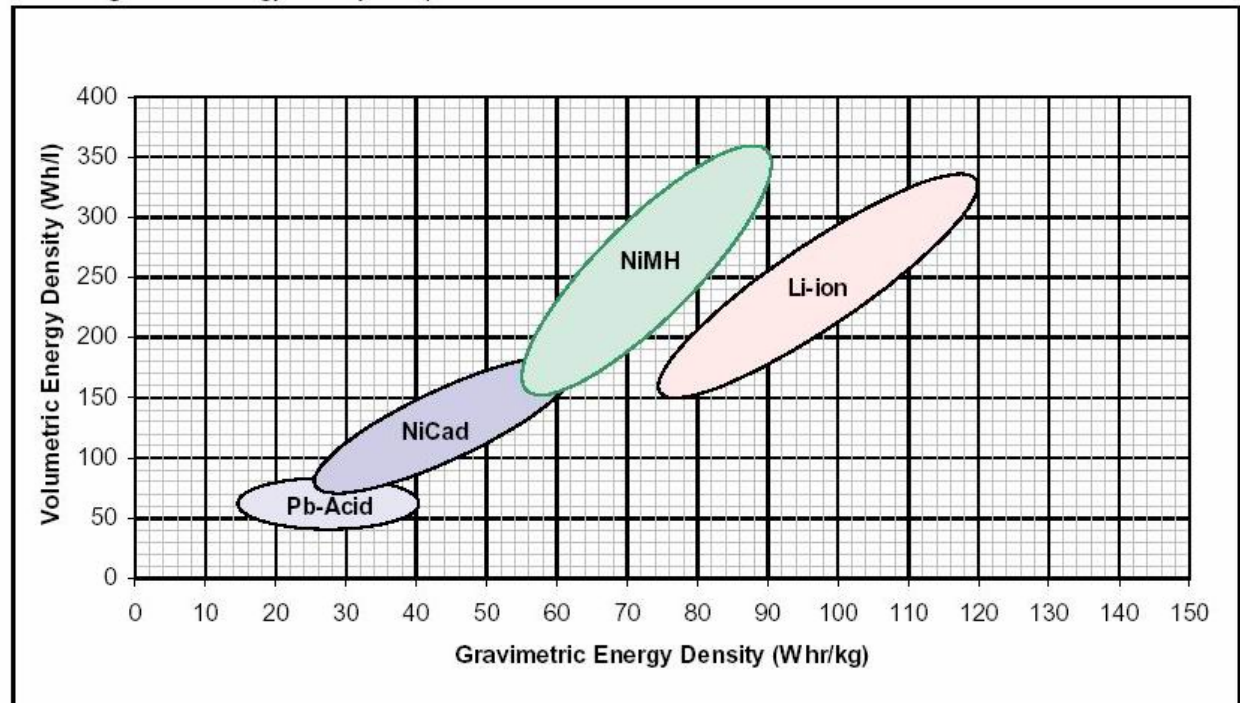

# Battery Characteristics

- Battery Capacity:
  - Measured in Amp-hours, rather than conventional Whr due to variation of battery voltage
  - Battery capacity depends on age and history of battery
- Depth of discharge
- Battery lifetime: Number of cycles
- Battery voltage and variation of voltage
- Effect of temperature

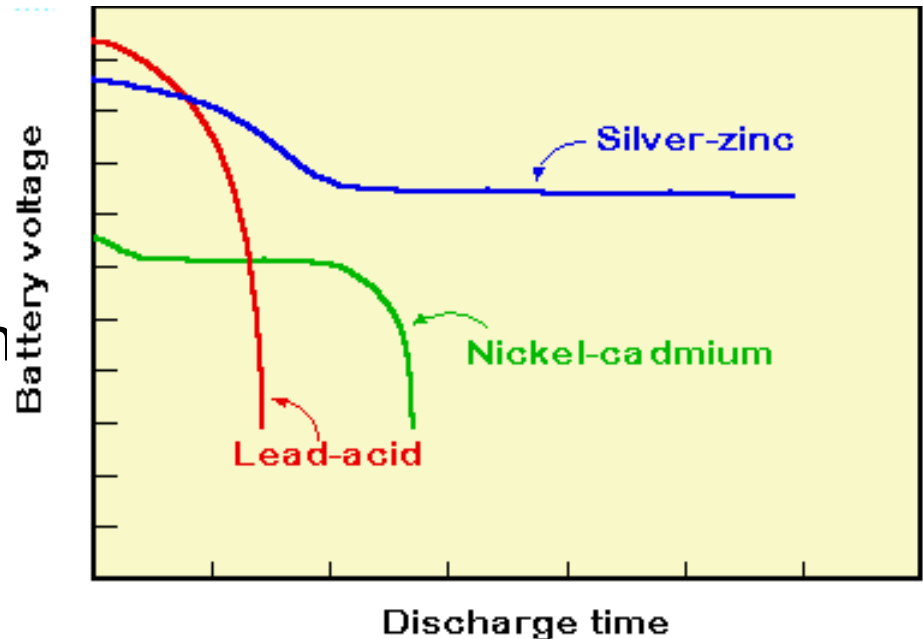

# Battery Systems: Lead Acid

- For secondary batteries, most common system is lead acid.
- Reaction and standard potential:



takes place in sulfuric acid, so get another reaction:

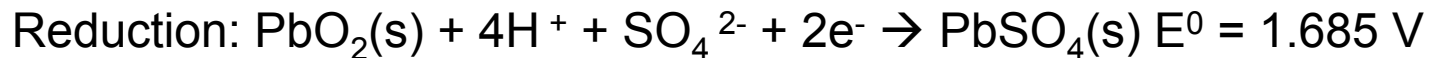
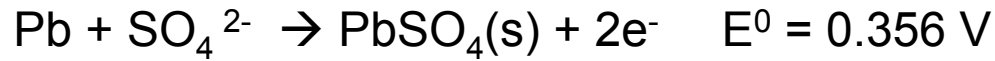
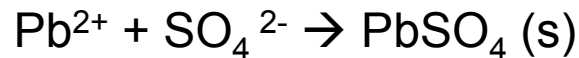

Overall:

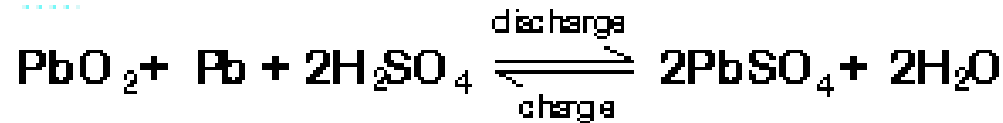

- Electrodes are lead oxide and “spongy” or porous lead
- Electrolyte is sulfuric acid
- Standard potential is 2.041V

# Lead Acid batteries

- Issues in lead acid batteries
  - Depth of discharge, lifetime and number of cycles

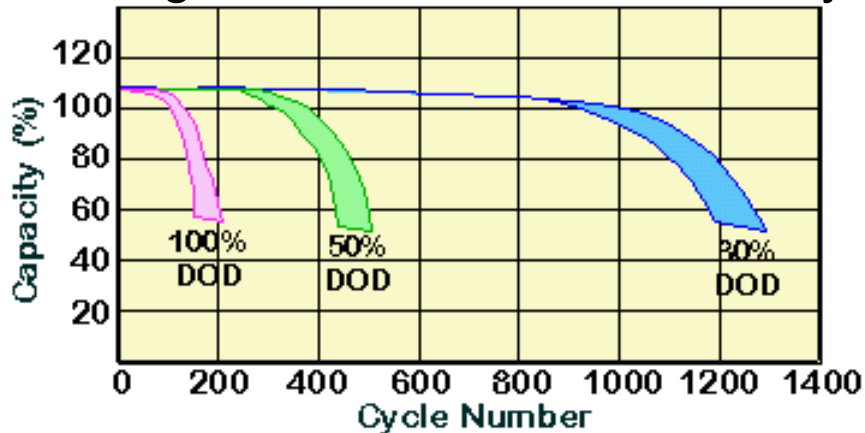

- Reduced life due to sulfation of the battery and shedding of plate material.
- Gassing of battery: high voltages or fast charging leads to electrolysis of water.

# Lead Acid batteries

- Issues in lead acid batteries
  - Stratification of the electrolyte: electrolyte cannot be readily mixed.
  - Physical damage to the electrodes due to soft electrode material
  - Spillage of sulfuric acid
    - Safety issue and problems in transport
  - Temperature dependence of the battery
    - Freezing of the battery at low temperatures
    - Increasing temperatures gives higher voltages, needs to be taken into account in charging and system design.

# Types of Lead Acid Batteries

- Batteries have modified electrode materials, geometry and electrolyte composition and volume to tailor battery to each application.
- Electrode composition and geometry:
  - Trace amounts of materials (antimony, calcium) added to lead plates increase hardness of battery, but affect gassing and depth of discharge of battery.
- Electrolyte
  - Increasing volume of electrolyte – less sensitive to water losses, but heavier.
  - Captive electrolyte: gelled or absorptive glass mat: can either be shallow or deep discharge, can be sealed.

# Types of Lead Acid Batteries

- Flooded batteries
  - Can add water, check status of electrolyte, etc.
  - Depending on configuration, can be shallow cycle or deep cycle.
- Sealed and valve regulated batteries
  - Often are gelled batteries.
  - Need to control charging regime carefully to prevent generation of hydrogen.
- Can also be classified by use: Starting, lighting, ignition (SLI); Motive power or traction; Marine or RV batteries; Stationary; Deep cycle

# Power Conditioning

- Power requirements and matching to PV module.
- Functions of power conditioning
  - Keep the module operating at its maximum power point (maximum power point trackers)
  - Optimize charging of the battery to prevent damage to the battery (battery charger)
  - Prevent battery from discharging through the solar modules (blocking diode)
  - Converting from DC power to AC power (inverter)

# Blocking diode

- Blocking diode is simply a diode in between modules and batteries.
- Must be sized to handle array current.
- Introduces a voltage loss in a system, which is significant (5% for a 12V system) for lower voltage systems not for higher voltages.
- Higher voltage (and therefore power) systems typically incorporate blocking diode in battery charge controller.

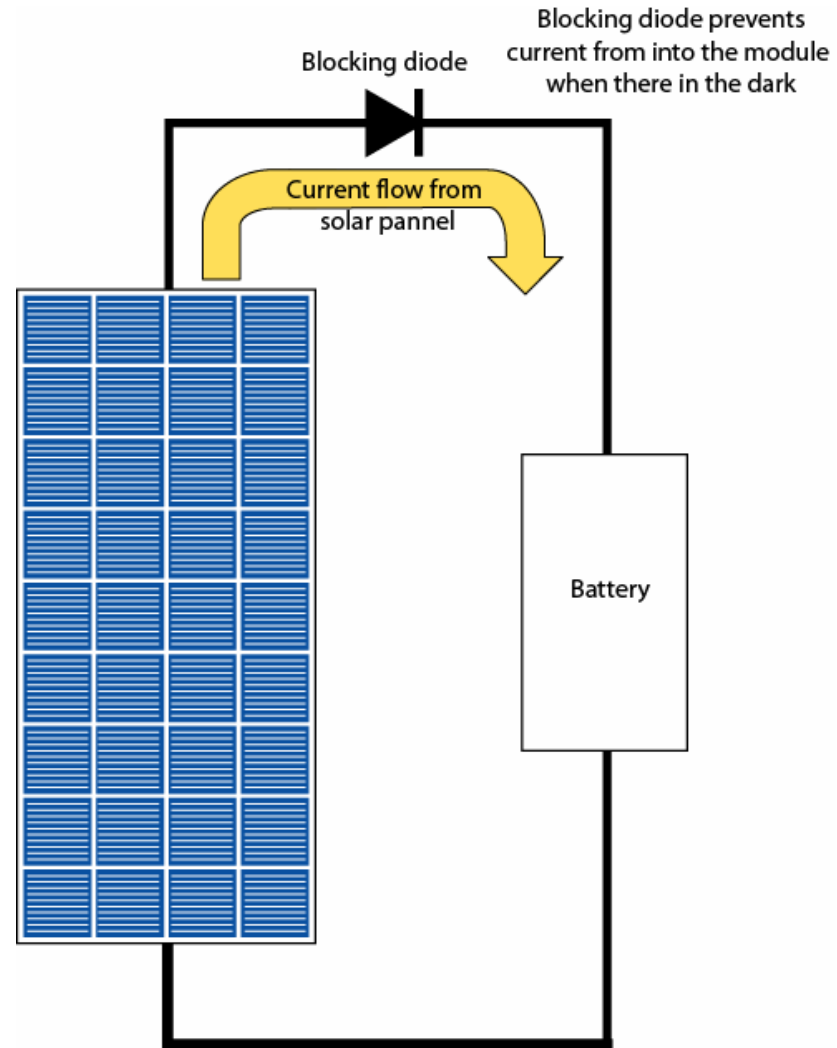

# Maximum power point tracking

- Function of MPPT is to maximize the power generated by the solar panel by ensuring it operates at its maximum power point.
- The characteristic resistance is defined as  $V_{mpp}/I_{mpp}$ , and equals the resistance of an load for which the PV panel operates at the maximum power point.

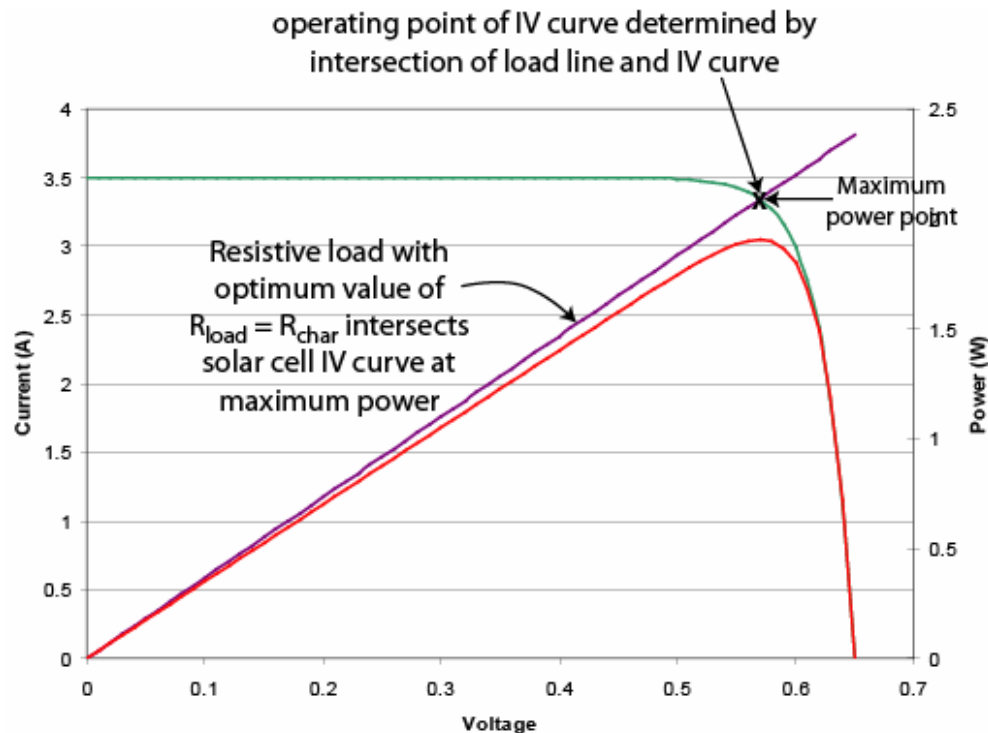

$$R_{char} = \frac{V_{mpp}}{I_{mpp}}$$

# Maximum power point tracking

- Constant power curves give  $I$  and  $V$  for a constant power
- The operating point of a PV module is given by the intersection of the load line and the module  $I$ - $V$  curve
- From constant power curve can determine how much power is lost when operating way from maximum power

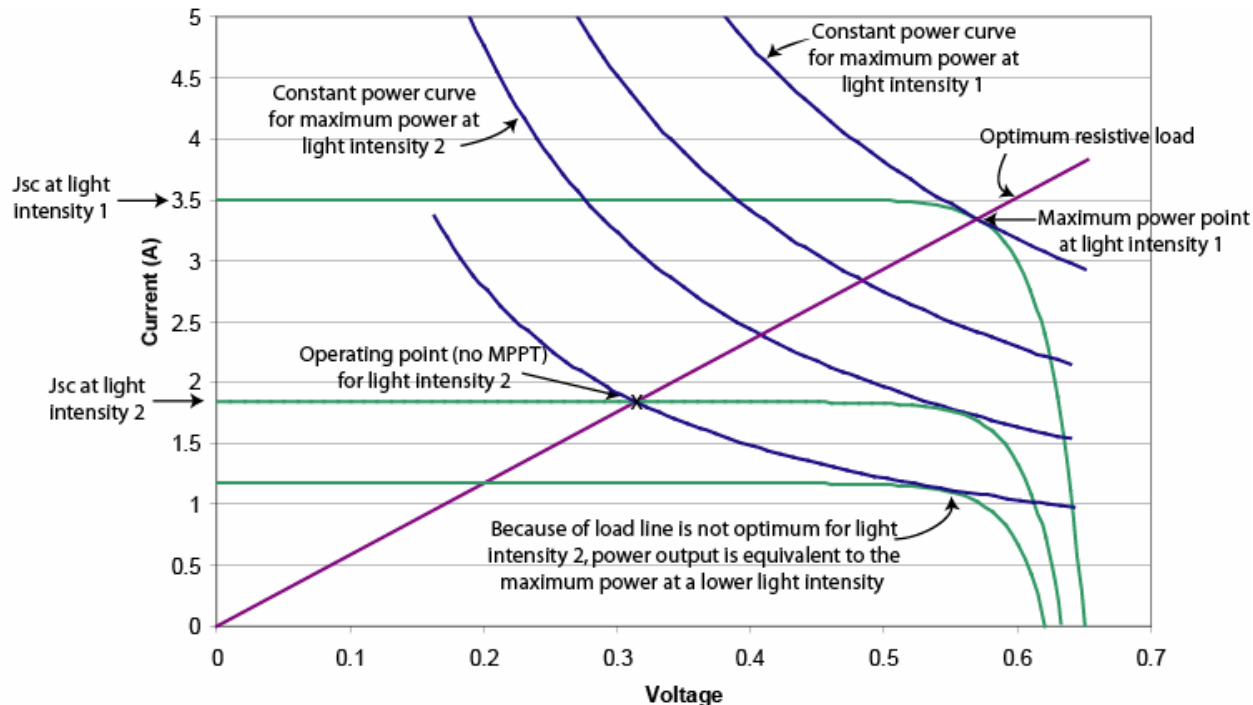

# Maximum power point tracking

- Maximum power point tracking (MPPT) allows PV module to operate at maximum power point as light intensity changes or as effective load resistance changes.
- MPPT consists of two components: a DC-DC converter and a circuit which searches for the maximum power point of the PV module, and ensures that the module is biased at MPP.
- MPPT have efficiencies >90%

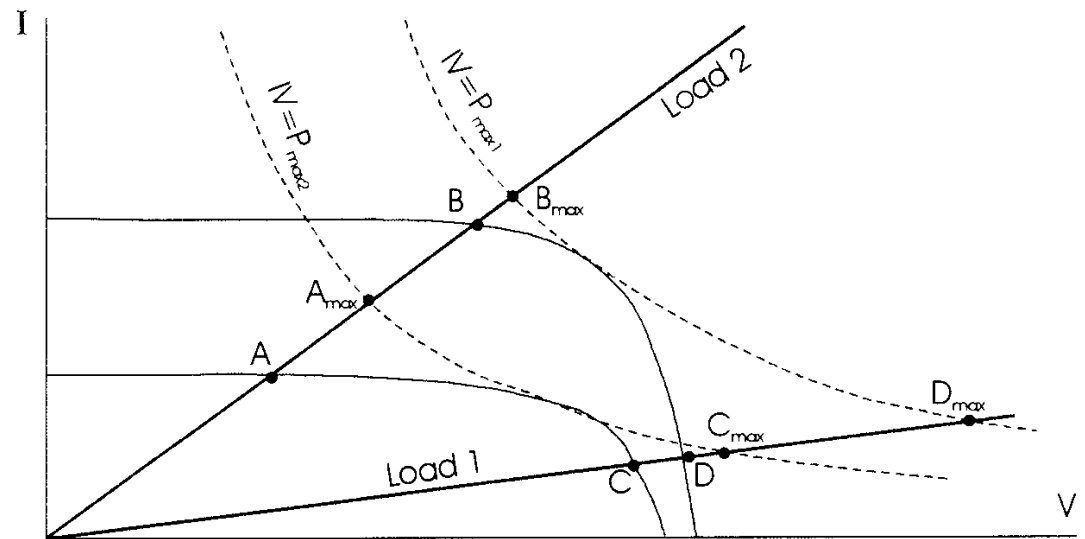

From Photovoltaic Systems Engineering.

# Battery Charging

- Batteries are very sensitive to charging parameters, and the lifetime of the battery can be dramatically altered by improper battery charging or leaving the battery at low charge
- Function of battery charger to provide appropriate charging conditions for the battery, particularly by preventing either overcharging or excessive discharging of the battery.
- The type of battery regulator must be matched to the battery used, and a battery charger designed for one type of battery will not be effective for another.

# Battery Charging

- Issues in battery charging:
  - If the charging current is too high, especially towards the end of charging, the current tends towards electrolysis of water (gassing) rather than charge storage.
  - However, if charging is stopped abruptly once gassing begins, the battery will not be charged to full capacity and where this happens consistently, the battery capacity will be reduced.
  - Solution is to taper of the charging current as the battery approaches full charge.
  - Charging to slowly also has disadvantages:
    - Low charging current increases possibility that current from solar array is wasted.
    - Need to be able to fully charge the battery while sunlight is available

# Battery Charging

- Battery charging approaches:
  - Constant voltage: Constant voltage applied. Simple method, but ineffective since either slow and does not reach full charge (if a low voltage is set) or allows essentially uncontrolled charging during initial charge (if high voltage is set).
  - Constant current: Not suited to lead-acid batteries, since high currents at end of charge cause gassing.
  - Multi-stage battery charging: Charging regime divided into several stages
    - **Bulk charge**, taking the battery from a low state of charge to close to fully charged state, often at relatively high rates of charge;
    - **Absorption charge**, more slowly charging the battery to its full state of charge, often under constant voltage mode;

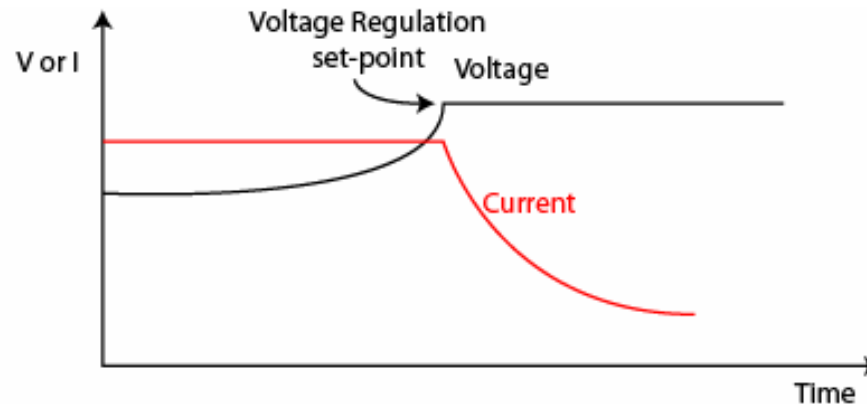

# Battery Charging

- Multi-stage battery charging: (con't)
  - **Maintenance charge during float operation**, keeping the battery fully charged by continuous low levels of current or by short bursts of power. Maintenance charging, also called float or trickle charging, is typically used from mid-day into late afternoon when the batteries may be fully charged; and
  - **Boost charging**, used only in open, flooded lead acid batteries to prevent stratification of electrolyte. If the electrolyte is gelled or absorbed in a AGM, boost charging should not be used.
- Pulsed charging: battery is given short pulses of charge, followed by a resting period. Allows charging to higher capacities while minimizing gassing.

# Battery charging

- Types of charging regimes:
  - Self-regulation:
    - Self-regulation does not employ a separate regulator but rather relies on the fact that as the battery voltage increases, the current available from a PV panel connected in parallel with the battery will decrease.
    - Will only work if the load, the solar insolation and module temperature all experience very little variation.
      - For example, in hot weather when the PV module experiences a lower voltage the battery may be undercharged, while under cold ambient temperatures the module voltage will be higher and may overcharge the battery.

# Battery charging

- Simple charging circuits:
- Shunt regulator:
  - When voltage reaches a certain level, shunt regulator turns on, and current is diverted through shunt.
  - Since shunt dissipates the power from the modules, only used for small systems where shunt can handle power flows.
- Series regulator: When a given voltage is reached, series switch opens. Does not allow reduced currents as voltage rises, and hence is not optimum charging

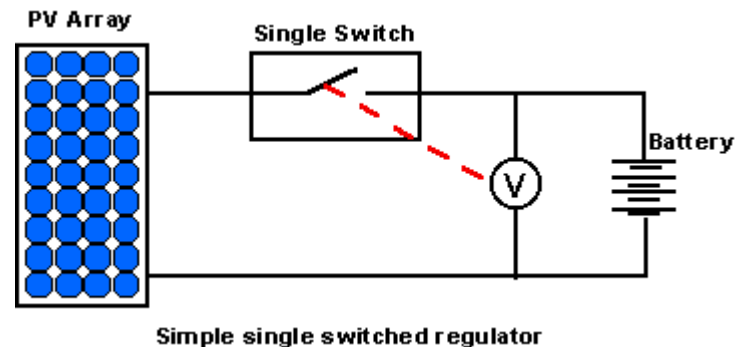
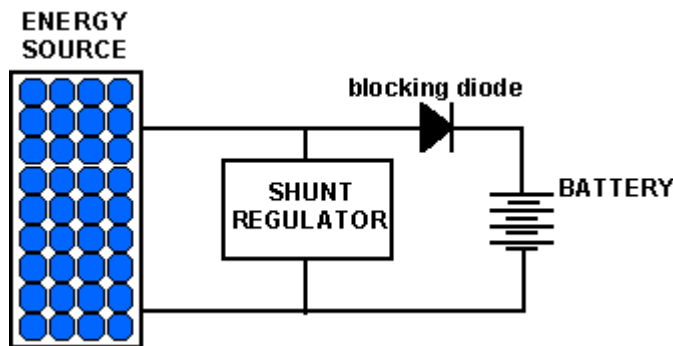

# Battery Charging

- Pulse Width Modulation Circuits:
  - A PWM circuit is used to provide a variable voltage, which allows greater control over types of charging methods.
  - Requires more complex circuitry than series or shunt charging.
- Amp-hour meters and controllers
  - The battery charger measures and controls the amp into and from the battery, and continuously determines the state-of-charge of the battery.
  - Allows potentially more precise information about BSOC, but requires periodic calibration.

# Inverters

- Function of inverter is to convert low voltage DC power from PV array to high voltage AC power as required by many loads.
- Characteristics of inverters
  - Power quality
    - Waveform shape
    - Total harmonic distortion
  - Input and output voltage ratings (input determined by battery voltage, output by that required by loads (typically 120V or 240V))
  - Power and surge power rating
  - Inverter efficiency
  - Connection and interaction of inverter with other AC components
    - Other inverters
    - Grid power

# Inverter

- Basic topology: DC  $\rightarrow$  AC conversion & AC voltage transformer
  - 2 basic approaches: High frequency transformer for AC voltage conversion & then high frequency to grid frequency (60 or 50 Hz)

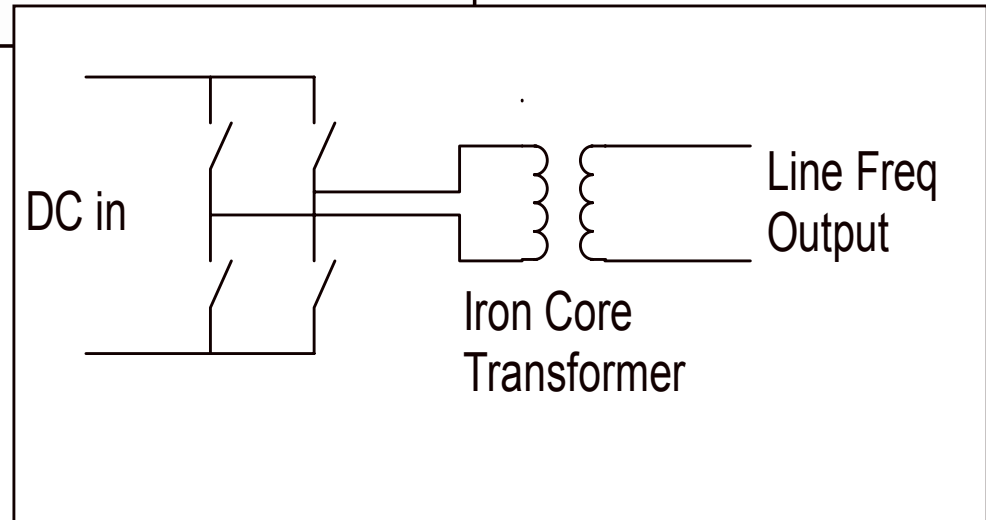
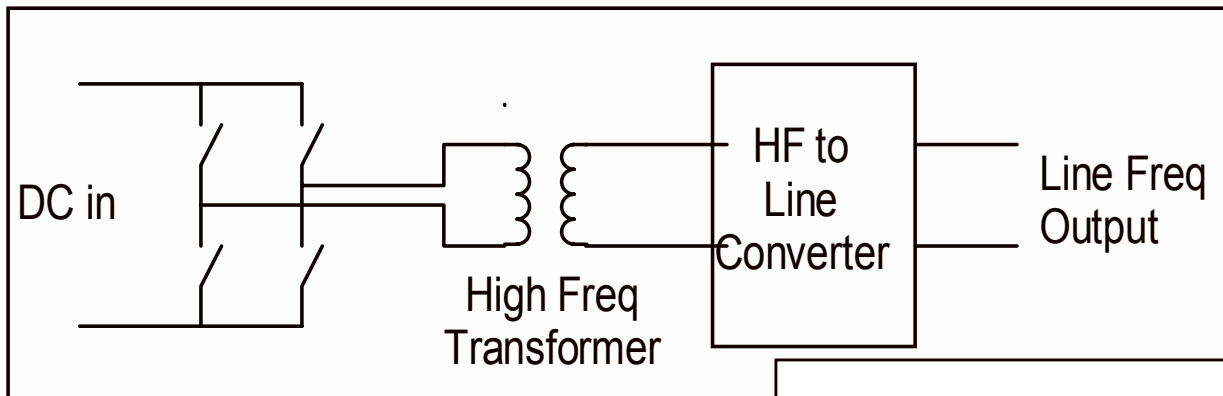

# Inverter

- Waveform:
  - Square wave output: simple, reliable & inexpensive, but very poor approximation to sine wave
  - Modified square wave
    - Also called quasi-sine wave
    - RMS and peak voltage are close to a sine wave
    - Still very high harmonic content and DC component in waveform
    - Relatively simple and inexpensive
  - Square wave & modified square wave not suited to sensitive loads

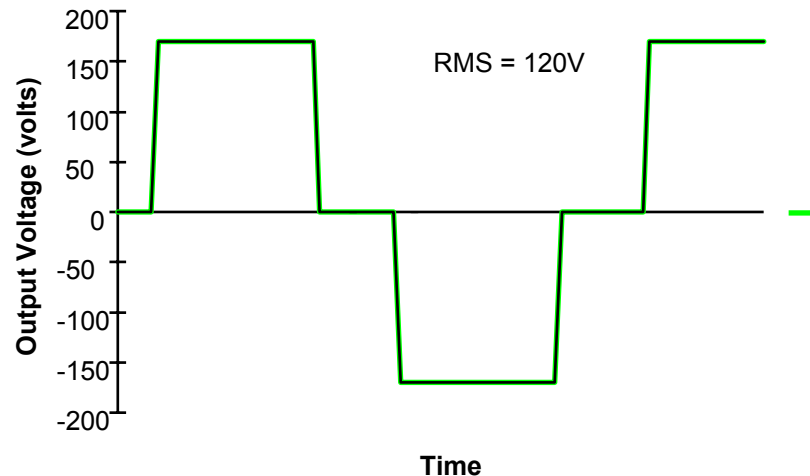
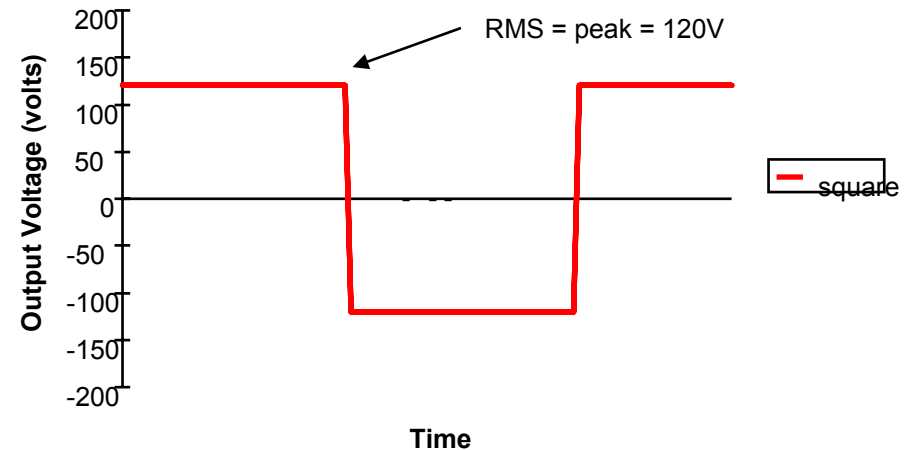

# Inverters

- Sine wave inverter
  - Reproduces sine wave of grid supply
  - Suitable for all loads
  - Can interact with other AC systems, such as generators and grid
  - Power output measured by total harmonic distortion (THD)
  - More complex circuitry.

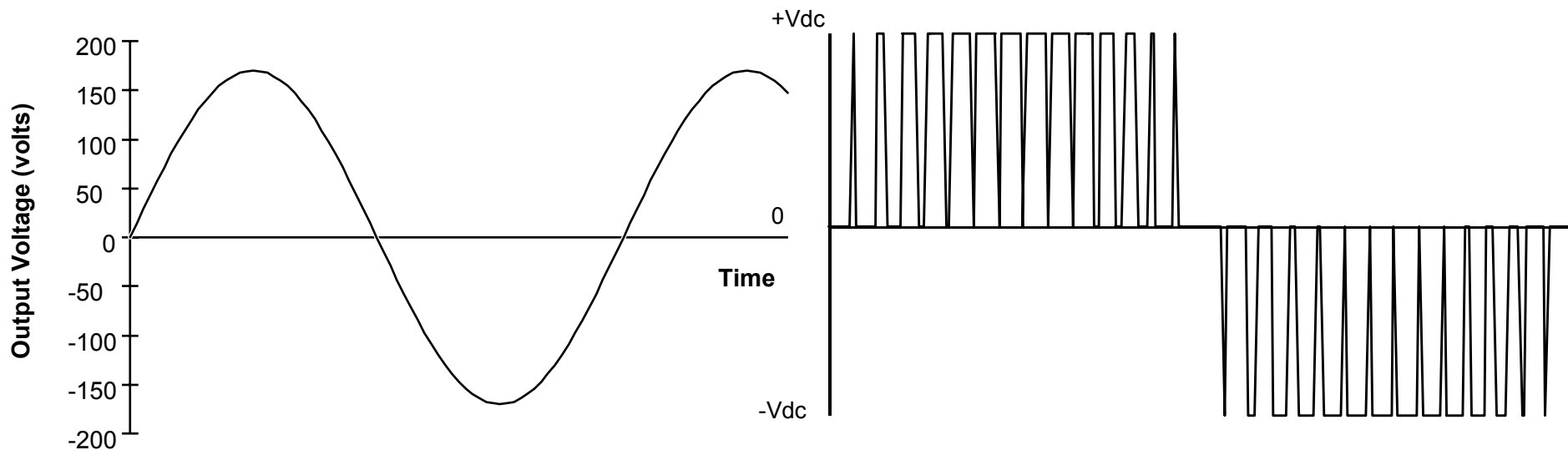

- Inverter Efficiency
  - Different types of inverters have substantially different performances away from rated power & will be matched to different load profiles
  - Best matched inverted depends on load characteristics: how high are the peaks; how long do they last; is there a light load for a large portion of the day; are there any seasonal variations in the daily load profile?

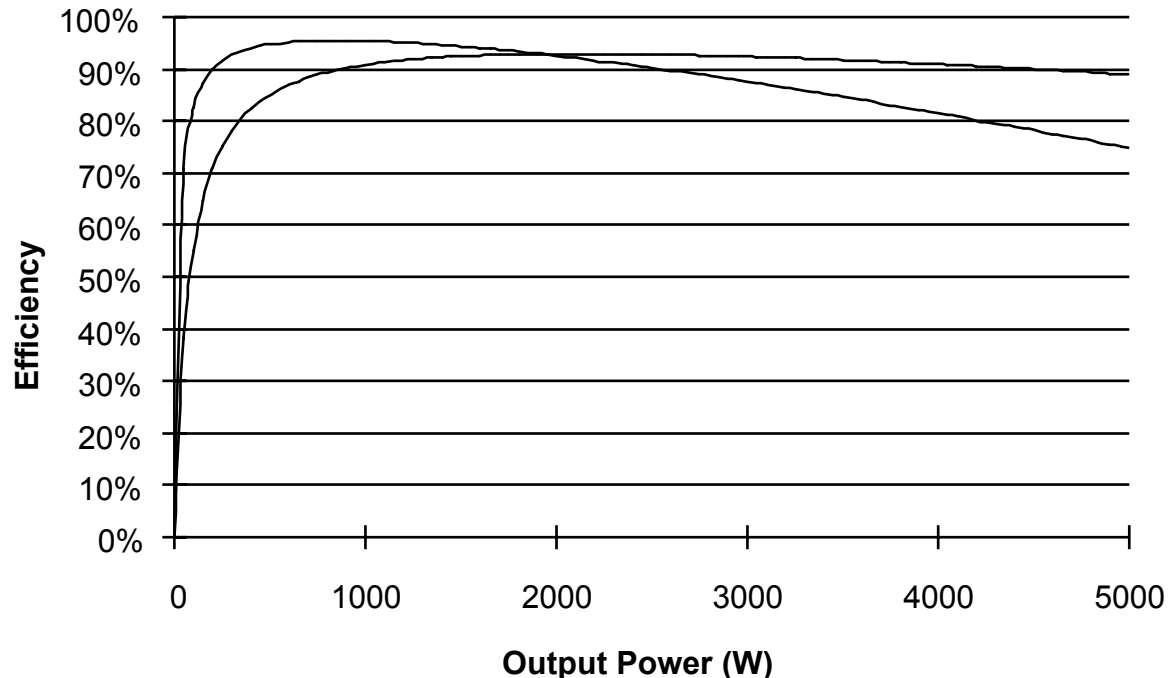

- Surge ratings of inverters
  - Inverter power loss is caused mainly by current flow.
  - Below the absolute current limit of the switching transistors, the current is limited by the temperature of the semiconductor junction.
  - Junction temp depends on ambient temp, power loss, and time.

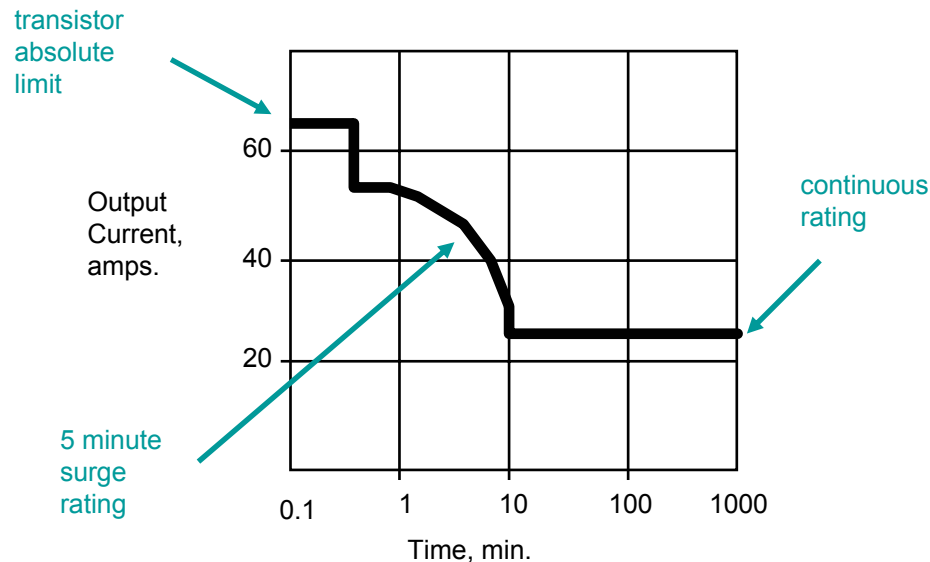

- Other inverter characteristics:
  - Parallelable :
    - inverters may be connected in parallel, to efficiently provide a greater power range than is possible with a single inverter
    - important when there is a large variation in the load which persists for substantial time periods
  - Bi-directional inverter:
    - Inverter can both provide power to the battery for charging, as well as source power from battery.
    - Bi directional inverters used when there are other power sources in the system, and these can also be used to charge battery.

# Inverters

- Two types of inverters: Stand alone and grid-tied
- Grid-tied inverters can include batteries, but many do not.
  - If no batteries, inverter can have different functionality – can perform maximum power point tracking for array (otherwise MPPT go between array and batteries), but the input voltage may vary by a greater amount than when batteries are present.
  - If batteries, grid can be considered another AC power source.
- Regulatory constraints of grid-tied inverters: Grid-tied inverters must meet specifications set by the utility.
  - Typically includes specifications on power quality
  - Islanding: if power failure occurs when PV array is producing power, a grid tied inverter may produce and “island” of live grid in the otherwise down grid lines.
    - Dangerous for workers of grid-line
    - Grid-tied inverters must have provision to isolate PV system from grid in event of power failure.

# Balance of System

- Anything else needed to complete the system, including:
  - Module mounting:
    - Module mounting may be either fixed or tracking
    - Tracking: modules track the sun, to give ~20% extra power throughout the year.
      - One-axis tracking: modules track the sun for one-axis (usually east-west)
      - Two-axis tracking: modules track sun both east-west and north-south. Usually not used in conventional PV systems – only used in concentrators.
  - Wiring, cabling
  - Housing for batteries, electronics
  - Land

# Loads

- Types of Loads:
  - Heating: Water heating, cooking, small appliances.
  - Motor/magnetic components: Examples: refrigeration, many other appliances
  - Lighting
  - Electronic circuits: Examples: TV, radio, VCR, clocks, etc.
  - Combination electronic /motor.

# Loads

- In determining load need to characterize:
  - Power used by load
  - AC/DC and possibility of variation (ie can get DC fridge if needed)
  - Power quality required: harmonic content, DC offset, peak voltage levels.
  - Variation of load in seasons.
  - Peak power used by entire load.
  - Variation of input voltage and current with time (ie surge current)
  - If load is “critical” (99% availability).
- Efficiency of loads
  - In general, efficiency of appliances, particularly motors, has been increasing over the last 5 years (20-30% increase in efficiency).
  - Need life cycle costing to determine if worth replacing with a newer or more efficient (possibly DC) appliance.

- Phantom loads

- Phantom loads are loads which, while typically quite small and not counted in load calculations have appreciable (and often unaccounted) power drain on the system
- Inverter efficiencies are typically not constant with power level (highest closest to their rated power), so continuous small loads appear to be much larger.
- Due to inverter efficiency, (say 10%) a 20W “phantom” load acts like a 200 W load.
- An increasing number of loads have continuous power requirements – typically anything with a clock, remote control, indicator lights.

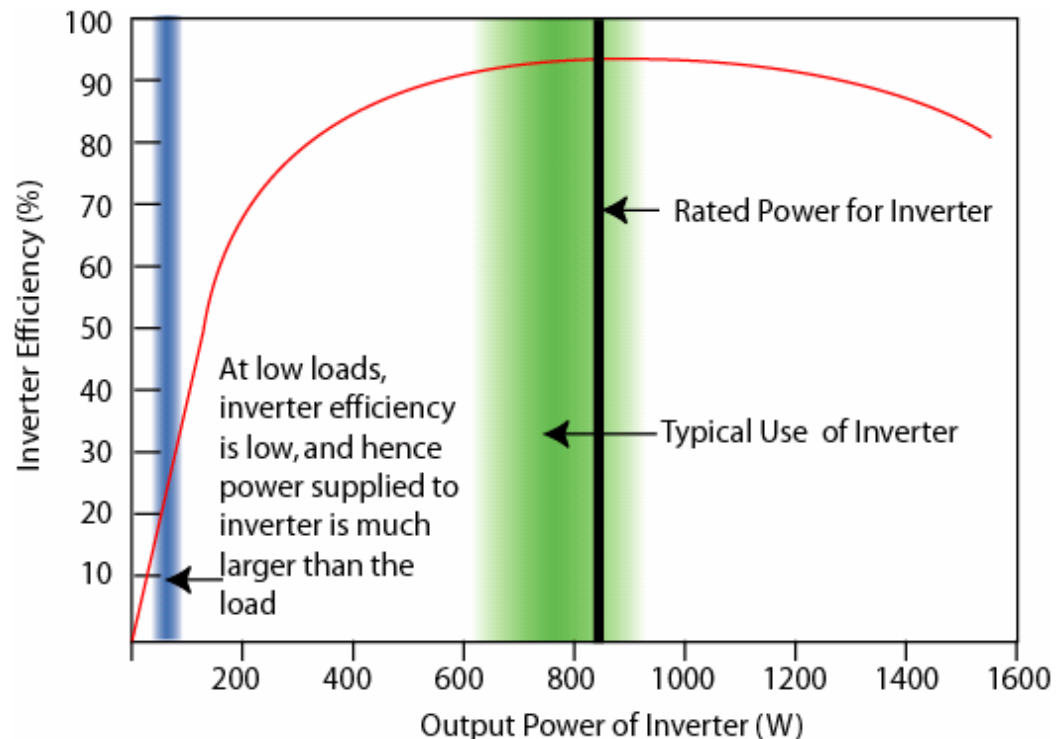

- Heating loads:
  - Heating generally energy intensive, and often can be accommodated in other fashions, eg water heating, house heating, some cooking.
  - Small heating loads usually not worth converting.
  - Key design principle is to eliminate as many heating loads as possible, primarily water heating and electric ranges.
- Electronics loads:
  - Examples: VCR, TV circuitry, etc.
  - May be damaged by peak voltages outside range of utility voltages.
  - Appliance may use power signal not only as a power source, but also as a timing signal:
    - Timing signal can be triggered by rising or falling voltage level of a waveform.
    - Noise, fluctuation, differences in slope of voltage waveform can all alter the triggering of the timing signal, disrupting operation of a range of electronic components, hence adding additional requirements to quality of output waveform.