

CPEG222 – Project 0

Fun with Assembly Language

For this introductory project, you will implement a simple LED counter display. A user will be able to Start/Stop/Reset the display. The project should be coded in “Assembly” using the CodeWarrior software. No additional hardware should be needed to complete this project.

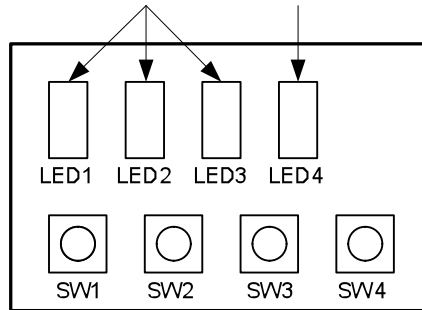

1. Display: 25 points

10 point deduction for each item not satisfied. Max deduction = 25 points.

- No flickering of display
- When flashing, LED's stay lit for a noticeable amount of time (~1 second)
- No interruption of display while pressing buttons

2. Operation: 60 points

20 point deduction for each item not satisfied. Max deduction = 60 points.

- Mode 1 – Reset/Initial
 - All LED's are OFF.
 - SW4 is pressed – enter Mode 2.
 - Ignore any button presses other than SW4.
- Mode 2 – Start
 - LED4 is ON.
 - LED1, LED2, LED3 count up in Binary, about once every second.
 - SW3 is pressed – enter Mode 3.
 - Ignore any button presses other than SW3.
- Mode 3 – Stop
 - LED4 is OFF.
 - LED1, LED2, LED3 remain showing last value.
 - SW4 is pressed – enter Mode2.
 - SW3 is pressed – remain in Mode3
 - Any other button presses (SW1, SW2) – enter Mode 1

3. Customer Satisfaction: 15 points

A 5 point deduction for each item below will be assessed. Max deduction = 15 points

- Incorrect/unexpected operation
- Unfamiliarity with any aspect of your project
- Late for your demo
- Poorly presented demo